

PRESTIGE®

Assembly Guide
Guide d'assemblage
Guía de ensamblaje
Montageanleitung

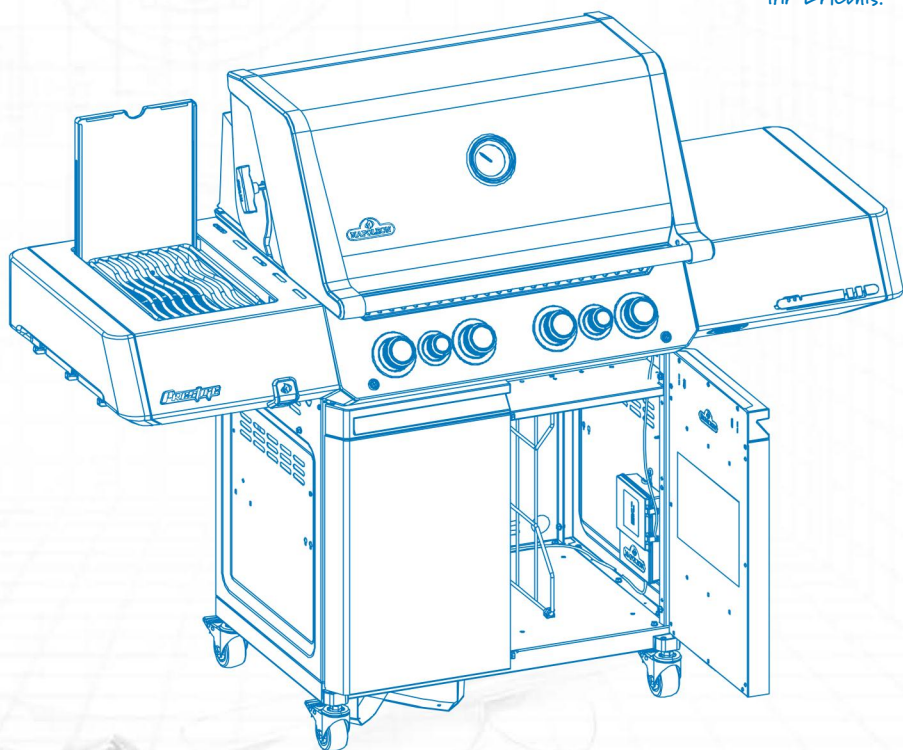

↑
*Upgrade your
experience.
Améliorez votre
expérience.
Mejora tu
experiencia.
Verbessern Sie
Ihr Erlebnis.*



EN Models FR Modèles ES Modelos DE Modelle
P500V | P500VX | P665V | P665VX



(EN) Assembly Guidelines | (FR) Guide de montage | (ES) Guía de instalación |
 (DK) Retningslinjer for montering | (DE) Leitlinien für die Montage |
 (FI) Kokoontapan-ohjeet | (CZ) Pokyny pro montáž | (SK) Pokyny pre montáž |
 (SI) Smernice za montažo | (UA) Посібник з монтажу | (PL) Wytyczne dotyczące
 montażu | (NO) Retningslinjer for montering | (NL) Richtlijnen voor montage |
 (IT) Linee guida per l'assemblaggio | (HR) Smjernice za sastavljanje |
 (GR) Οδηγίες συναρμολόγησης

- | | |
|----------------------------------|-----------------------------|
| (EN) Safety requirements | (UA) Вимоги безпеки |
| (FR) Exigences de sécurité | (PL) Wymogi bezpieczeństwa |
| (ES) Requerimientos de seguridad | (NO) Sikkerhetskrav |
| (DK) Krav til sikkerhed | (NL) Veiligheidseisen |
| (DE) Sicherheitsanforderungen | (IT) Requisiti di sicurezza |
| (FI) Turvallisuusvaatimukset | (HR) Sigurnosni zahtjevi |
| (CZ) Bezpečnostní požadavky | (GR) Απαιτήσεις ασφαλείας |
| (SK) Bezpečnostné požiadavky | |
| (SI) Varnostne zahteve | |
| (SE) Säkerhetskrav | |



- | | |
|--|--|
| (EN) Installation tools (not included) | (UA) Інструменти для встановлення
(не входять до комплекту) |
| (FR) Outils d'installation (non inclus) | (PL) Narzędzia montażowe
(brak w zestawie) |
| (ES) Herramientas de instalación
(no incluidas) | (NO) Installasjonsverktøy (ikke inkludert) |
| (DK) Installationsværktøj (medfølger ikke) | (NL) Installatiegereedschap
(niet meegeleverd) |
| (DE) Montagewerkzeug (nicht enthalten) | (IT) Strumenti di installazione (non
inclusi) |
| (FI) Asennustyökalut (eivät sisälly) | (HR) Alati za instalaciju (nisu uključeni) |
| (CZ) Instalační nářadí (není součástí balení) | (GR) Εργαλεία εγκατάστασης
(δεν περιλαμβάνονται) |
| (SK) Inštaláčne náradie
(nie je súčasťou dodávky) | |
| (SI) Orodja za namestitve (niso vključena) | |
| (SE) Installationsverktyg (ingår ej) | |



3/8
(10 mm)

3/8
(10 mm)

Legend | Légende | Leyenda | Legende | Legende | Selite | Legenda |
 Legenda | Legenda | Легенда | Legenda | Legende | Legende |
 Leggenda | Legenda | Υπόμνημα



Tool included
 Outil inclus
 Herramienta incluida
 Krav til sikkerhed
 Sicherheitsanforderungen
 Työkälu mukana
 Bezpečnostní požadavky
 Bezpečnostné požiadavky
 Varnostne zahteve

Säkerhetskrav
 Інструмент у комплекті
 Wymogi bezpieczeństwa
 Sikkerhetskrav
 Veiligheidseisen
 Requisiti di sicurezza
 Sigurnosni zahtjevi
 Απαιτήσεις ασφαλείας



VX models only
 Modèles VX
 uniquement
 Sólo para modelos VX
 Kun VX-modeller
 Nur VX-Modelle

Vain VX-mallit
 Pouze modely VX
 Len modely VX
 Samo modeli VX
 Endast VX-modeller
 Тільки моделі VX

Tylko modele VX
 Kun VX-modeller
 Alleen VX-modellen
 Solo modelli VX
 Samo VX modeli
 Μοντέλα VX μόνο



Warning!
 Avertissement !
 ¡Advertencia!
 Advarsel!
 Warnung!

Varoitus!
 Varování!
 Varovanie!
 Opozorilo!
 Varning!

Обережно!
 Ostrzeżenie!
 Advarsel!
 Waarschuwing!
 Attenzione!

Upozorenje!
 Προειδοποίηση!



Caution!
 Attention !
 ¡Precaución!
 Forsigtig!

Vorsicht!
 Varoitus!
 Pozor!
 Pozor!

Varning!
 Обережно!
 Uwaga!
 Forsiktig!

Let op!
 Attenzione!
 Oppez!
 Προσοχή!



Cut here
 Coupez ici
 Corte aquí
 Klip her

Hier schneiden
 Leikkaa tästä
 Střih zde
 Tu vystrihnúť

Prenehajte tukaj
 Зніміть тут.
 Przeciąć tutaj
 Kutt her.

Hier snijden.
 Tagliare qui.
 Reži ovdje.
 Κόψτε εδώ.



Critical position.
 Position critique.
 Posición crítica
 Kritisk position.
 Kritische Stelle.
 Kriittinen sijainti.
 Kritická poloha.
 Kritická poloha.
 Kriični položaj.
 Критична

позиция.
 Rozycja krytyczna.
 Kritisk posisjon.
 Kriteike positie.
 Posizione critica.

Kritična pozicija.
 Κρίσιμη θέση.



Propane only.
Propane uniquement.
Sólo propano.
Kun propan.
Nur Propan.
Vain propani.
Pouze propan.
Len na propán.
Samo za propan.

Тільки пропан.
Tylo propan.
Kun propan.
Alleen propan.
Solo propano.
Samo propan.
Μόνο προπάνιο.



Natural Gas.
Gaz naturel.
Gas natural.
Naturgas.
Maakaasu.
Zemní plyn.
Zemný plyn.
Zemljski plin.

Природний газ.
Gaz ziemny.
Naturgass.
Aardgas.
Gas naturale.
Φυσικό αέριο.



Magnetic attachment.
Fixation magnétique.
Accesorio magnético.
Magnetisk fastgørelse.
Magnetische Befestigung.
Magneettikiinnitys.
Magnetické upevnění.
Magnetické pripevnenie.

Magnetna pritrditev.
Магнітне кріплення.
Mocowanie magnetyczne.
Magnetisk feste.
Magnetische bevestiging.
Attacco magnetico.
Μαγνητική σύνδεση.



Handle with care.
Manipuler avec précaution.
Manipular con cuidado.
Håndter med forsigtighed.
Vorsichtig handhaben.
Käsitlele varoen.
Zacházejte opatrně.
Opatrne manipulujte.

Previdno ravnanje.
Поводьтєся з ним обережно.
Należy obchodzić się ostrożnie.
Håndteres med forsigtighet.
Voorzichtig behandelen.
Maneggiare con cura.
Pazite pri rukovanju.
Χειριστείτε με προσοχή.



Remove protective film.
Retirer le film protecteur.
Retire la película protectora.
Fjern beskyttelsesfilmen.
Beschermfolie verwijderen.
Rimuovere la pellicola protettiva.
Uklonite zaštitni film.
Αφαιρέστε την προστατευτική μεμβράνη.
Odstraňte ochrannou fólii.
Odstraňte ochrannú fóliu.
Odstranite zaščitno folijo.

Зніміть захисну плівку.
Usunąć folię ochronną.
Fjern beskyttelsesfilmen.
Beschermfolie verwijderen.
Rimuovere la pellicola protettiva.
Uklonite zaštitni film.
Αφαιρέστε την προστατευτική μεμβράνη.



Repeat step.
Répétez l'étape.
Repite el paso.
Gentag trinnet.
Wiederholen Sie den Schritt.
Toista vaihe.
Krok opakujcie.
Krok zopakujcie.

Ponovite korak.
Повторити крок.
Powtórz krok.
Gjenta trinnet.
Herhaal stap.
Ripetere il passaggio.
Επαναλάβετε το βήμα.



Look closely!
Regarder attentivement!
¡Mira de cerca!
Se godt efter!
Schauen Sie genau hin!
Katso tarkkaan!
Podívejte se pozorně!
Pozrite sa pozorne!

Poglejte pozornost!
Дивись уважно!
Przyjrzyj się uważnie!
Se nøye etter!
Kijk goed!
Guardate bene!
Κοιτάξτε προσεκτικά!

WELCOME TO NAPOLEON!

Congratulations on upgrading your grilling game and welcome to the **NAPOLEON** family!



Ready to assemble your new grill?



There may be visual differences between illustrations and model purchased. Remove all parts from packaging before assembling the barbecue. Set up this assembly on a solid, level and horizontal surface.

BIENVENUE À NAPOLEON!

Félicitations pour votre achat et bienvenue dans la famille **NAPOLEON**!



Prêt à assembler votre nouveau grill?



Veillez noter qu'il peut y avoir des différences entre les illustrations de ce guide et le modèle acheté. Retirez toutes les pièces de leur emballage avant de commencer. Veillez à assembler votre grill sur une surface plane et solide.

¡BIENVENIDO A NAPOLEON!

¡Felicidades por mejorar tu juego de parrilla y bienvenido a la familia **NAPOLEON**!



¿Listo para ensamblar tu nueva parrilla?



Tenga en consideración que puede haber diferencias entre las ilustraciones en esta guía y el modelo adquirido. Remueva todas las piezas de sus empaques antes de comenzar. Asegúrese de ensamblar la parrilla en una superficie plana y sólida.

VELKOMMEN TIL NAPOLEON!

Tillykke med, at du har opgraderet dit grillspil, og velkommen til **NAPOLEON**-familien!



Er du klar til at samle din nye grill?



Der kan være visuelle forskelle mellem illustrationer og den købte model. Tag alle dele ud af emballagen, før du samler grillen. Stil grillen op på en solid, plan og vandret overflade.

WILLKOMMEN BEI NAPOLEON!

Herzlichen Glückwunsch zur Aufrüstung Ihres Grills und willkommen in der **NAPOLEON**-Familie!



Sind Sie bereit, Ihren neuen Grill zusammenzubauen?



Es kann optische Unterschiede zwischen den Abbildungen und dem gekauften Modell geben. Nehmen Sie vor dem Zusammenbau des Grills alle Teile aus der Verpackung. Stellen Sie die Baugruppe auf einer festen, ebenen und horizontalen Fläche auf.

TERVETULOA NAPOLEONIIN!

Onnittelut grillauspelisi päivittämisestä ja tervetuloa **NAPOLEON**-perheeseen!



Oletko valmis kokoamaan uuden grillisi?



Kuivissa ja ostetussa mallissa voi olla visuaalisia eroja. Poista kaikki osat pakkauksesta ennen grillin kokoamista. Aseta tämä kokoonpano kiinteälle, tasaiselle ja vaakasuoralle alustalle.

VÍTEJTE V NAPOLEONU!

Blahopřejeme vám k vylepšení vaší grilovací hry a vítáme vás v rodině **NAPOLEON!**



Jste připraveni sestavit svůj nový gril?



Mezi ilustracemi a zakoupeným modelem mohou být vizuální rozdíly. Před sestavením grilu vyjměte všechny díly z obalu. Tuto sestavu postavte na pevný, rovný a vodorovný povrch.

VITAJTE V NAPOLEONE!

Blahoželáme vám k vylepšení vašej grilovacej hry a vítáme vás v rodine **NAPOLEON!**



Ste pripravení zostaviť svoj nový gril?



Medzi ilustráciami a zakúpeným modelom môžu byť vizuálne rozdiely. Pred zostavením grilu vyberte všetky diely z obalu. Túto zostavu postavte na pevný, rovný a vodorovný povrch.

DOBRODOŠLI V NAPOLEONU!

Čestitamo vam, da ste izboljšali svojo igro na žaru, in vas pozdravljamo v družini **NAPOLEON!**



Ste pripravljeni na montažo svojega novega žara?



Med ilustracijami in kupljenim modelom so lahko vizualne razlike. Pred sestavljanjem žara odstranite vse dele iz embalaže. Ta sklop postavite na trdno, ravno in vodoravno površino.

VÄLKOMMEN TILL NAPOLEON!

Grattis till att du har uppgraderat din grillning och välkommen till **NAPOLEON**-familjen!



Är du redo att montera din nya grill?



Det kan förekomma visuella skillnader mellan illustrationer och den modell som köpts. Ta bort alla delar från förpackningen innan du monterar grillen. Ställ upp enheten på ett stabilt, plant och horisontellt underlag.

ЛАСКАВО ПРОСИМО НА НАПОЛЕОН!

Вітаємо з оновленням вашого гриля та ласкаво просимо до сім'ї **NAPOLEON**!



Готові зібрати свій новий гриль?



Можливі візуальні відмінності між ілюстраціями та придбаною моделлю. Вийміть всі деталі з упаковки, перш ніж збирати гриль. Встановіть цю збірку на тверду, рівну і горизонтальну поверхню.

WITAMY W NAPOLEON!

Gratulujemy ulepszenia swojego grilla i witamy w rodzinie **NAPOLEON**!



Gotowy do montażu nowego grilla?



Mogą występować różnice wizualne między ilustracjami a zakupionym modelem. Przed złożeniem grilla należy wyjąć wszystkie części z opakowania. Ustaw urządzenie na solidnej, równej i poziomej powierzchni.

VELKOMMEN TIL NAPOLEON!

Gratulerer med oppgraderingen av grillspillet ditt, og velkommen til **NAPOLEON**-familien!



Er du klar til å montere din nye grill?



Det kan være visuelle forskjeller mellom illustrasjonene og modellen du har kjøpt. Ta alle delene ut av emballasjen før du monterer grillen. Sett opp denne enheten på en solid, jevn og vannrett overflate.

WELKOM BIJ NAPOLEON!

Gefeliciteerd met het upgraden van uw grill spel en welkom bij de **NAPOLEON** familie!



Klaar om uw nieuwe grill te monteren?



Er kunnen visuele verschillen zijn tussen de illustraties en het gekochte model. Haal alle onderdelen uit de verpakking voordat u de barbecue in elkaar zet. Zet dit geheel op een stevige, vlakke en horizontale ondergrond.

BENVENUTO A NAPOLEON!

Congratulazioni per aver migliorato il vostro gioco di grigliate e benvenuti nella famiglia **NAPOLEON**!



Siete pronti ad assemblare il vostro nuovo grill?



Potrebbero esserci differenze visive tra le illustrazioni e il modello acquistato. Rimuovere tutte le parti dall'imballaggio prima di assemblare il barbecue. Posizionare il gruppo su una superficie solida, piana e orizzontale.

DOBRODOŠLI U NAPOLEON!

Čestitamo na unapređenju vaše igre roštiljanja i dobrodošli u **NAPOLEON** obitelji!



Spremni za sastavljanje vašeg novog roštilja?



Može biti vizualnih razlika između ilustracija i kupljenog modela. Uklonite sve dijelove iz pakiranja prije sastavljanja roštilja. Postavite ovu montažu na čvrstu, ravnu i vodoravnu površinu.

ΚΑΛΩΣ ΗΡΘΑΤΕ ΣΤΟ ΝΑΠΟΛΕΟΝΤΑ!

Συγχαρητήρια για την αναβάθμιση του παιχνιδιού ψησίματος και καλωσορίσατε στην οικογένεια **NAPOLEON**!



Είστε έτοιμοι να συναρμολογήσετε τη νέα σας ψησταριά;



Ενδέχεται να υπάρχουν οπτικές διαφορές μεταξύ των απεικονίσεων και του μοντέλου που αγοράσατε. Αφαιρέστε όλα τα εξαρτήματα από τη συσκευασία πριν συναρμολογήσετε το μπάμπηκιου. Τοποθετήστε αυτό το συγκρότημα σε μια σταθερή, επίπεδη και οριζόντια επιφάνεια.

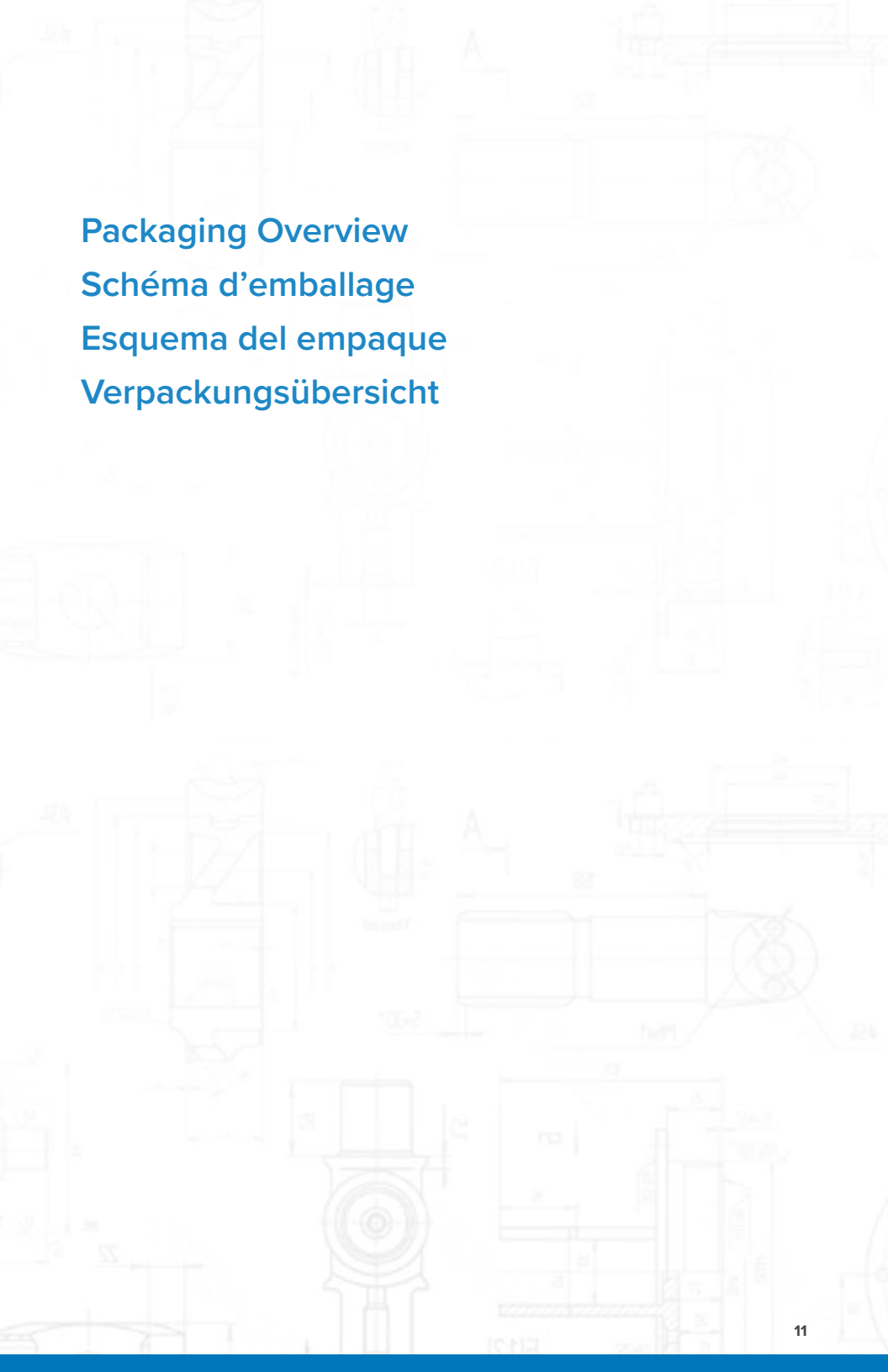

The background of the page is a light gray technical drawing. It features various mechanical components, including shafts, gears, and housing parts, shown in both perspective and cross-sectional views. Dimensions and labels like 'A' are visible throughout the drawing.

Packaging Overview
Schéma d’emballage
Esquema del empaque
Verpackungsübersicht

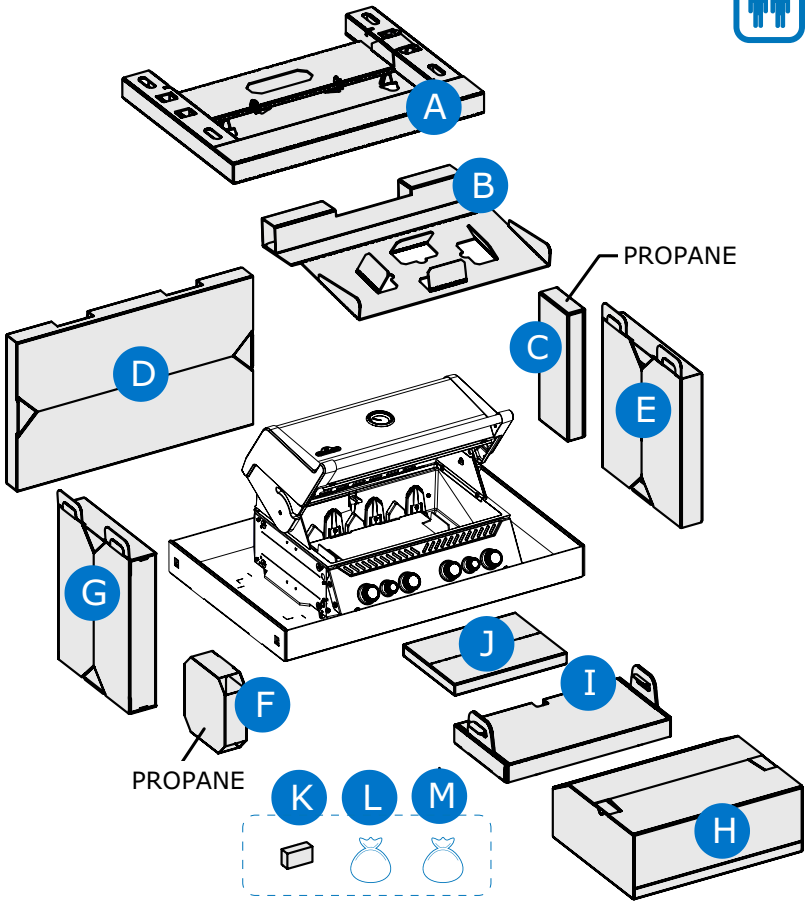

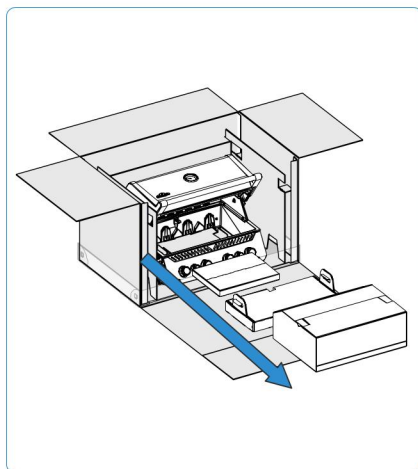
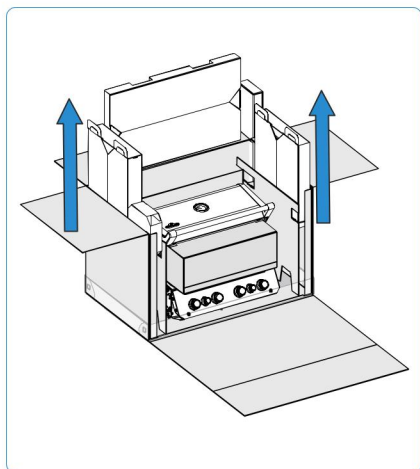
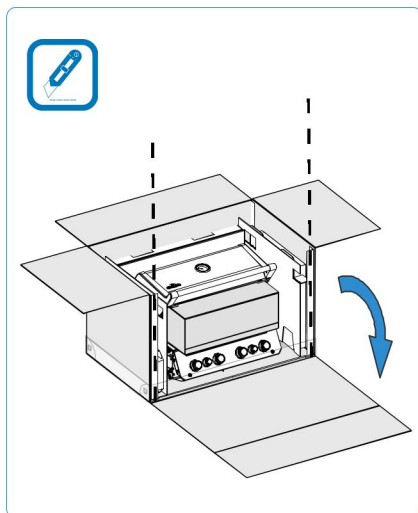
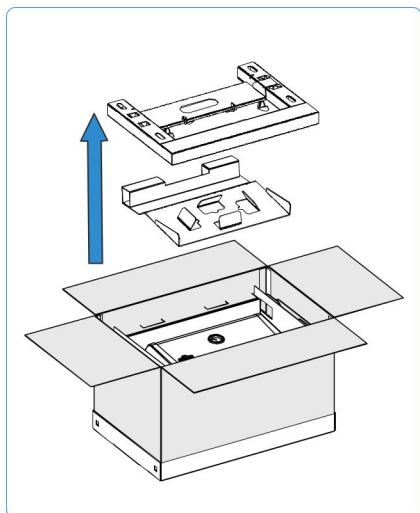

P500V



P500VX

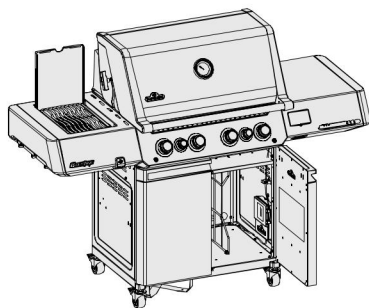

P665V

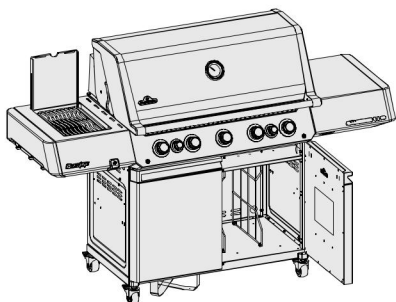

P665VX

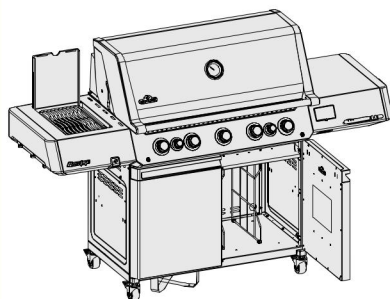

A

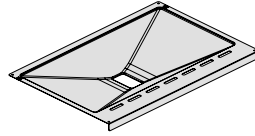
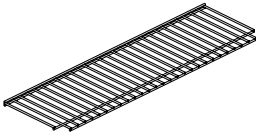

B

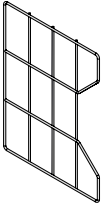

x1 P500
x2 P665

C

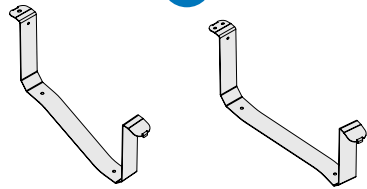

D

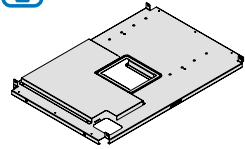
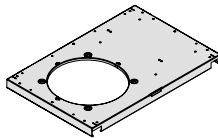
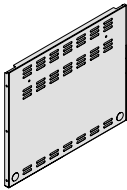

E

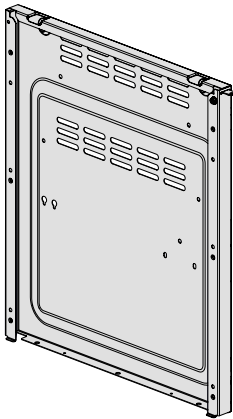

x1

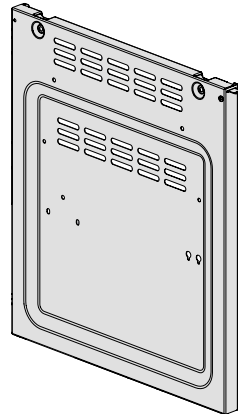

x1

F

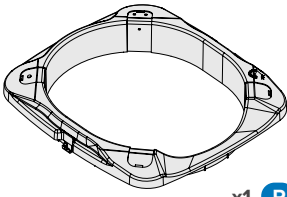

x1 P

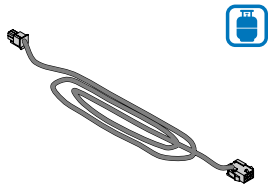
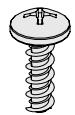

x1 PVX

G

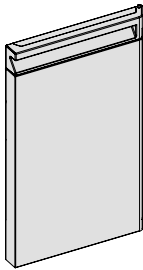
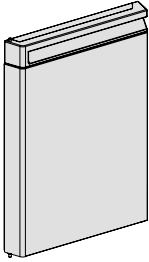

H

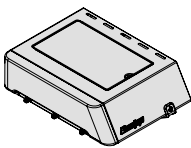

x1

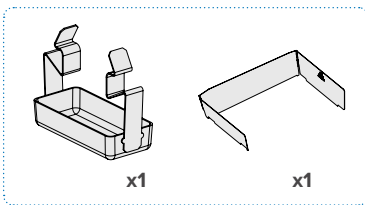

x1

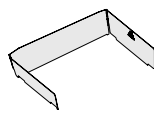

x1

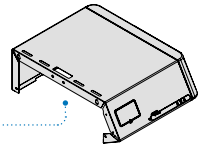

x1

J

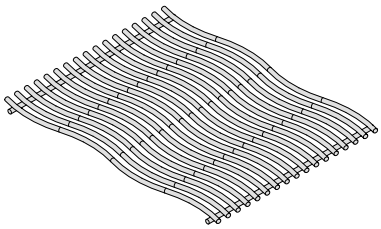

x2

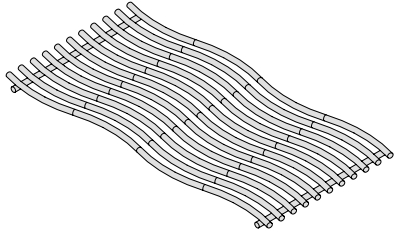

x1 P665

I

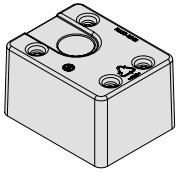

x2

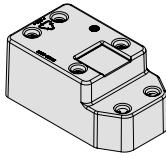

x2

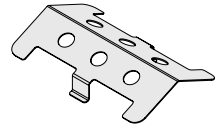

x1 **P665**

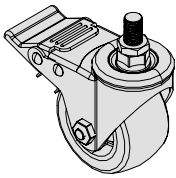

x4

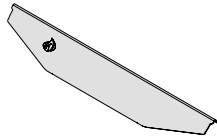

x7 **P500**

x9 **P665**

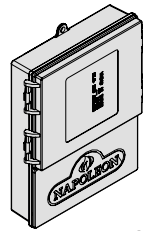

x1

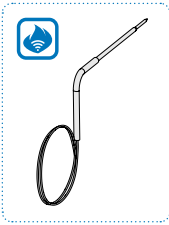

x3

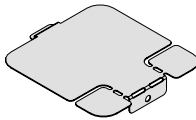

x1



x3

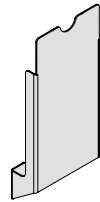

x1

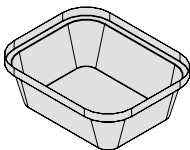

x1

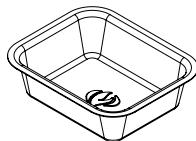

x1

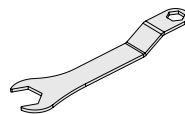

x1

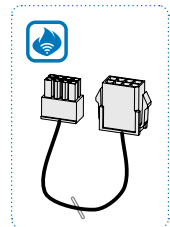

x1

Kit Contents | Contenu du kit | Contenido del kit | Inhalt des Kits

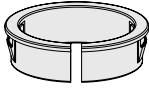

x1



x2

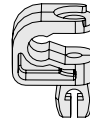

x4 P500

x8 P665



x2 P500

x4 P665

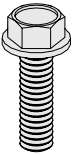

x30



x10



x8



x1

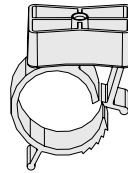

x1



x8

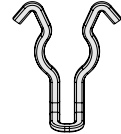

x1

K

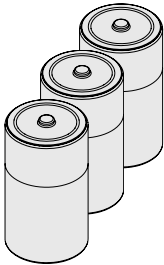

x1 Box P500/665V

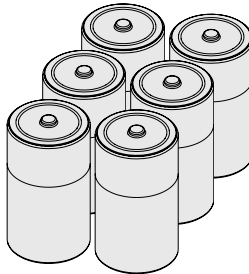

x2 Box P500/665VX

The background of the page is a light gray technical drawing of a mechanical assembly. It includes various views such as side elevations, cross-sections, and end views. Dimensions are indicated with lines and numbers, and some parts are labeled with letters like 'A' and 'B'. The drawing is detailed, showing threads, chamfers, and specific fit requirements.

Assembly Steps

Étapes de l'installation

Pasos para la instalación

Montage-Schritte

1

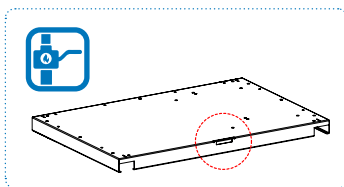
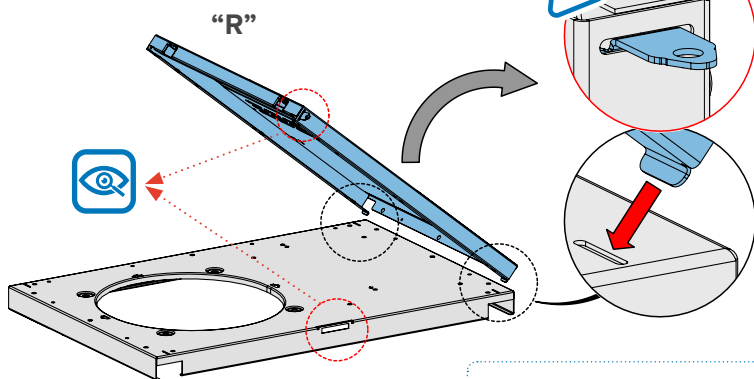

2

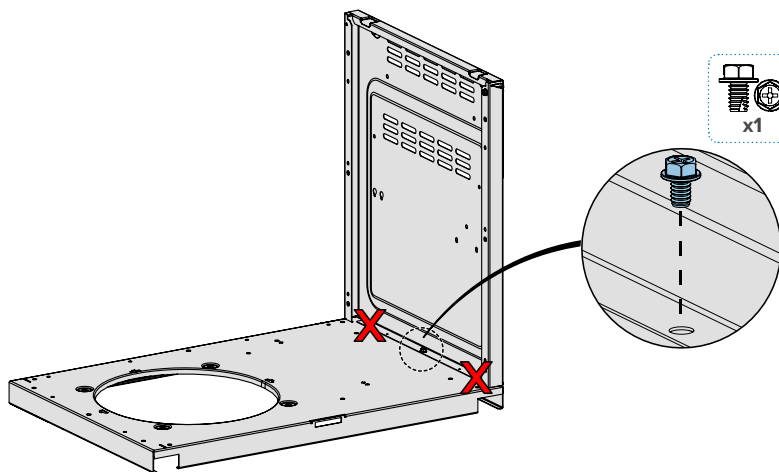

3

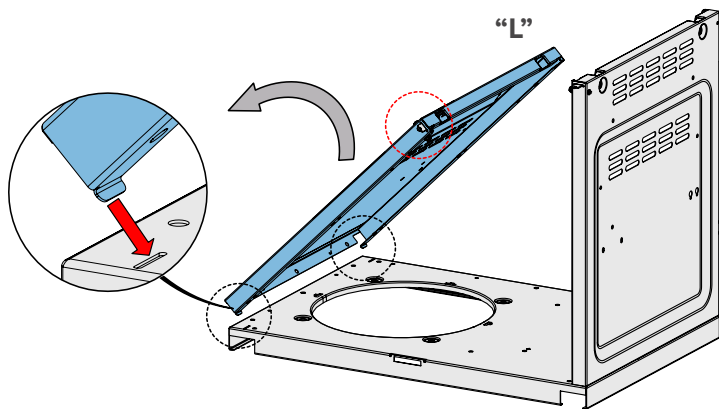

4

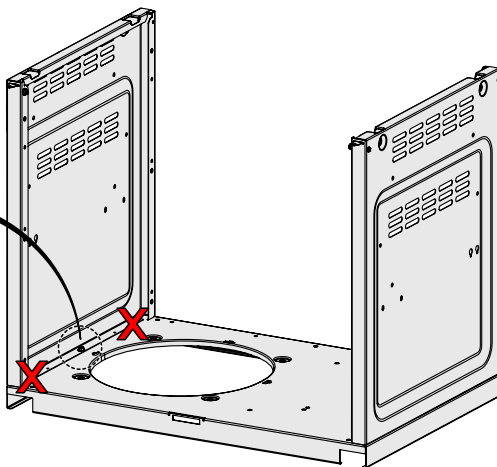
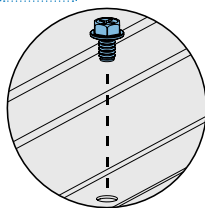

5

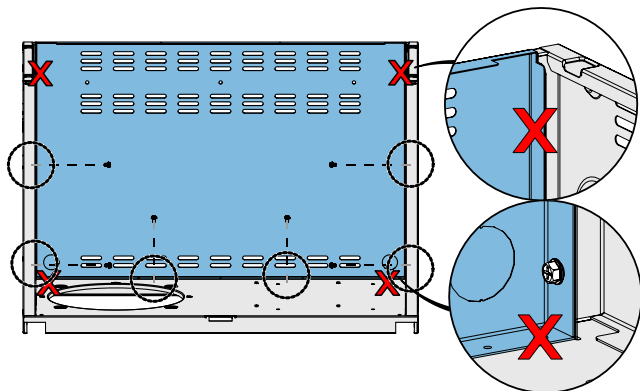
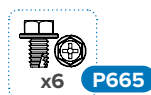
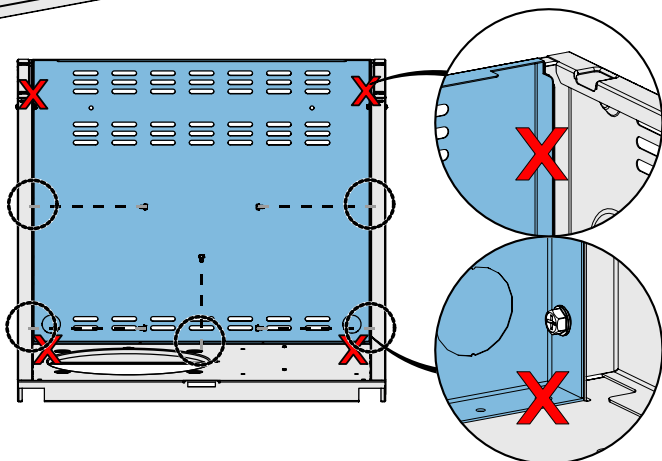
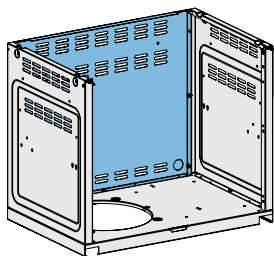

6

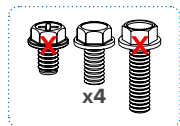
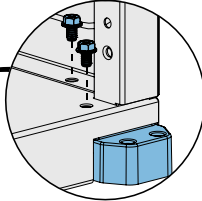
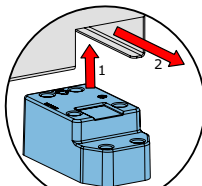
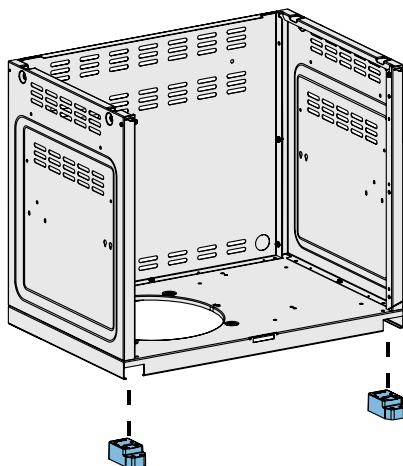

7

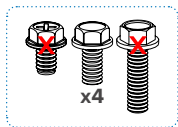
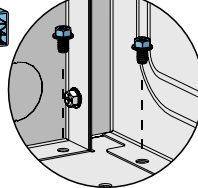
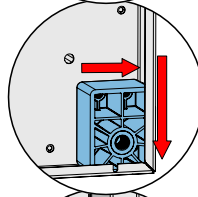
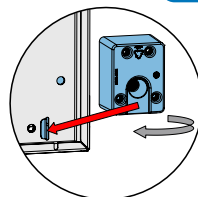
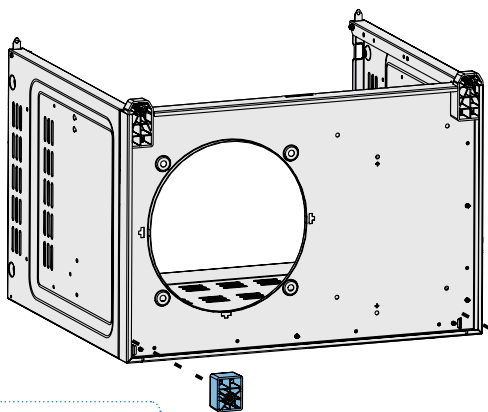

8

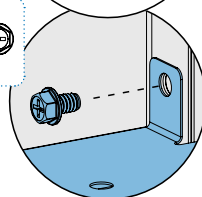
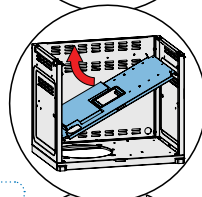
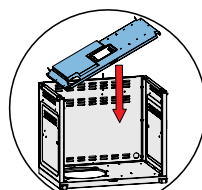
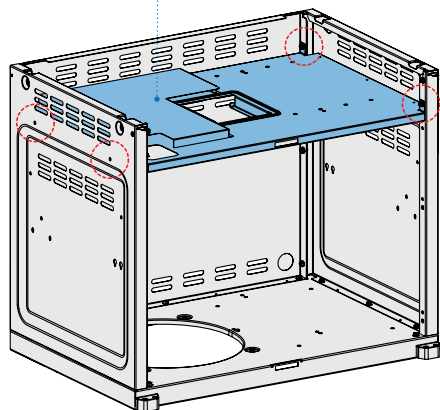
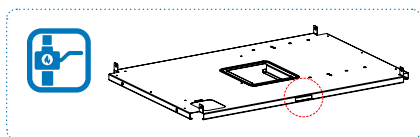

9

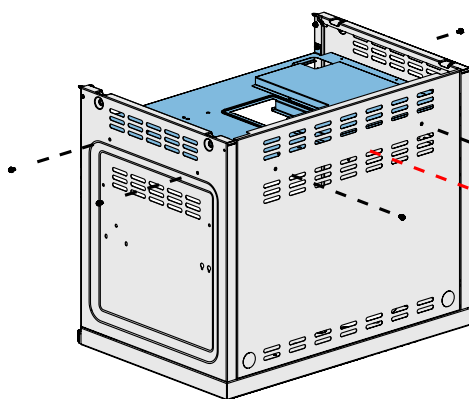

10

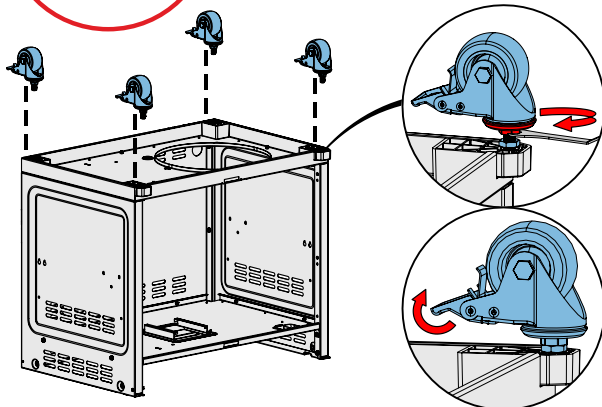
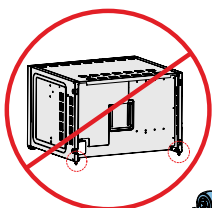

11

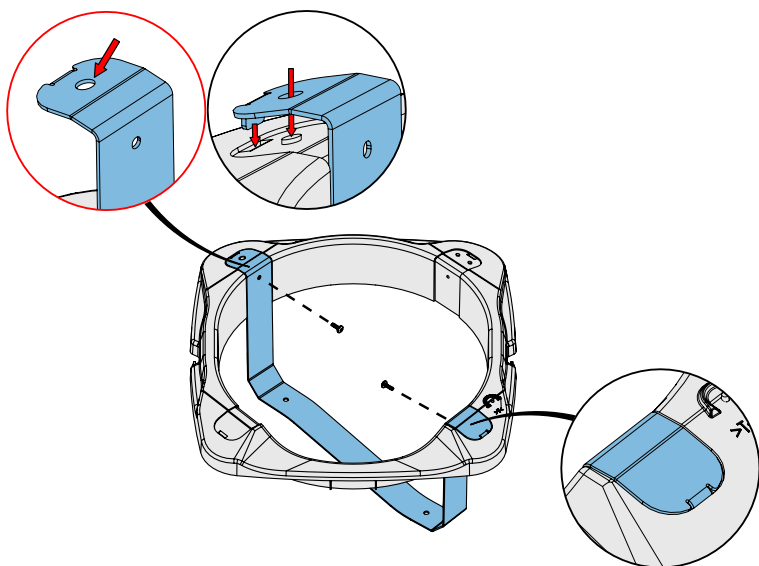

12

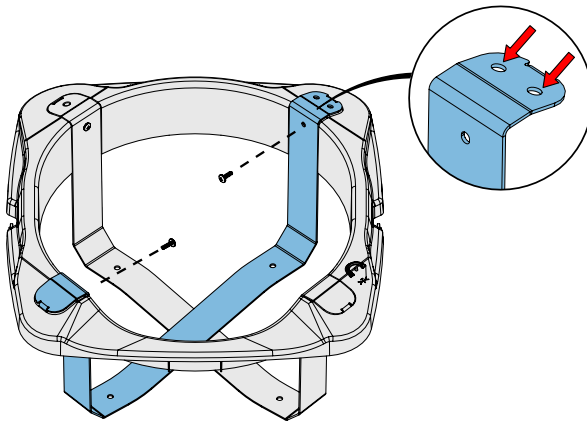

13

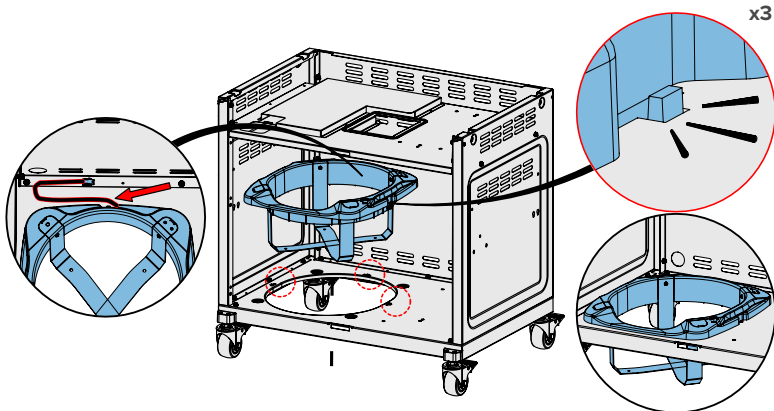

- EN Ensure wires are not pinched during installation.
- FR Veiller à ce que les fils ne soient pas pincés lors de l'installation.
- ES Asegúrese de que los cables no queden aprisionados durante la instalación.
- DE Achten Sie darauf, dass die Drähte bei der Installation nicht eingeklemmt werden.

14



x4 P500

x8 P665

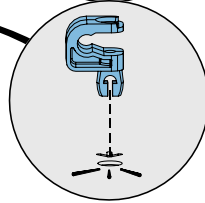
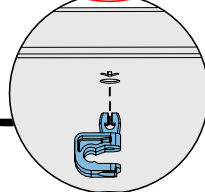
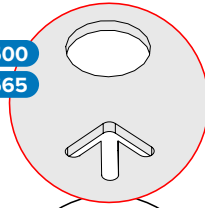
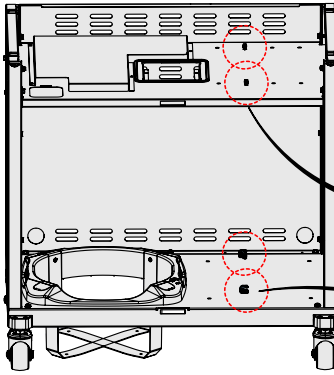

15

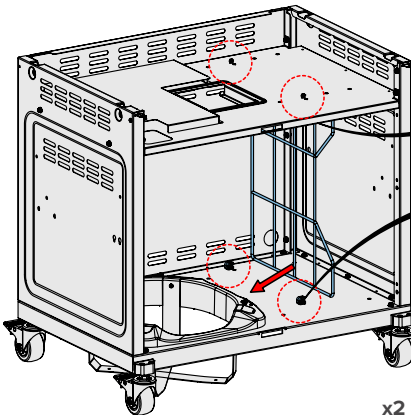

x2 P665

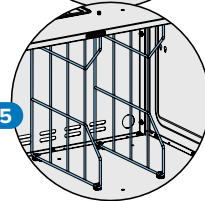
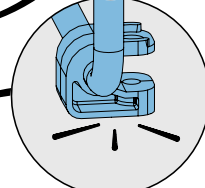
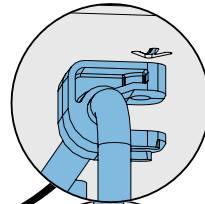

16

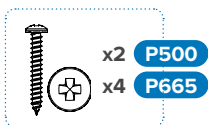
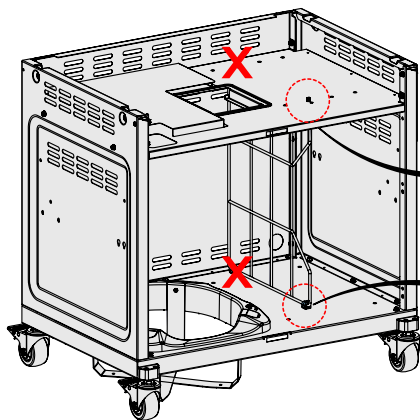

17

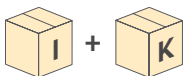

P500V P665V

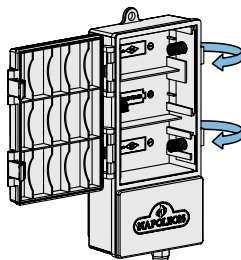

P500VX P665VX

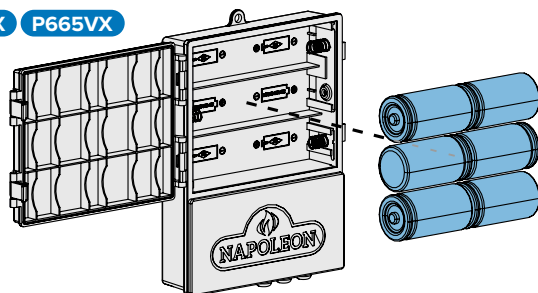

18

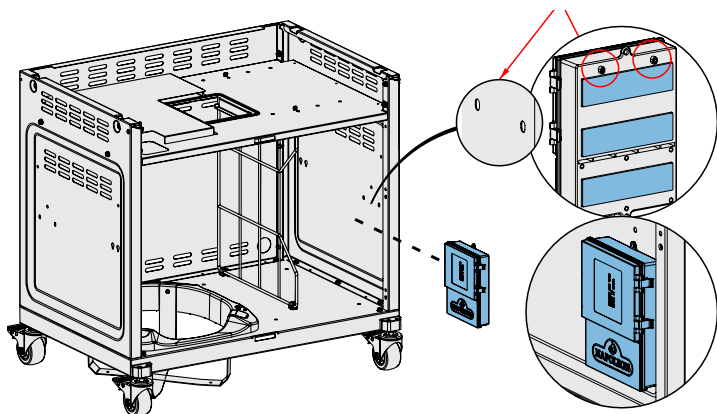

19

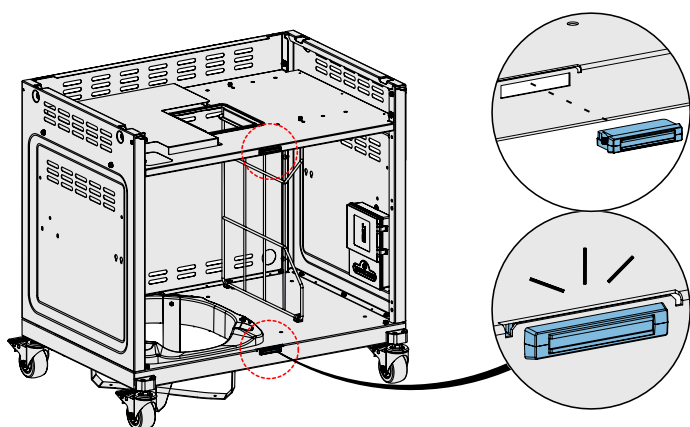

20

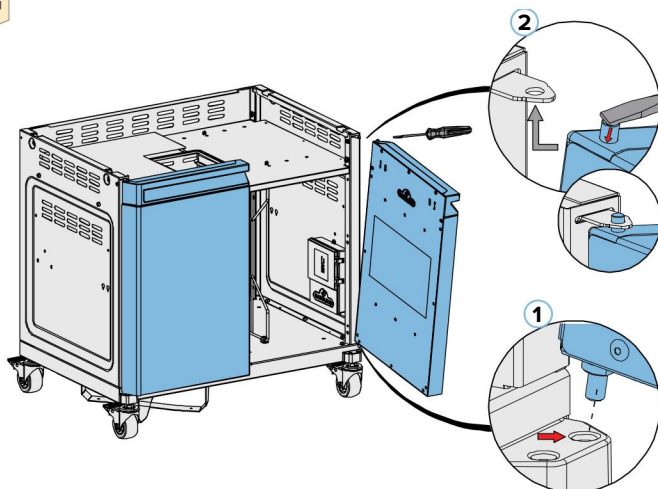

21

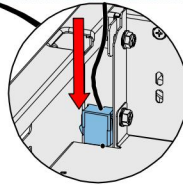
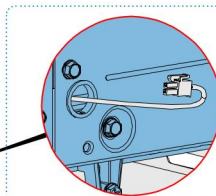
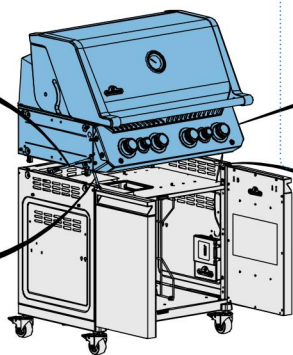
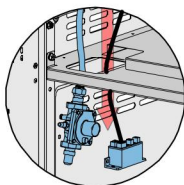
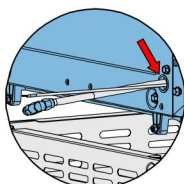
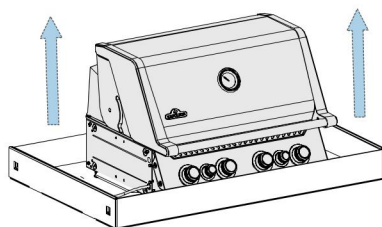

22

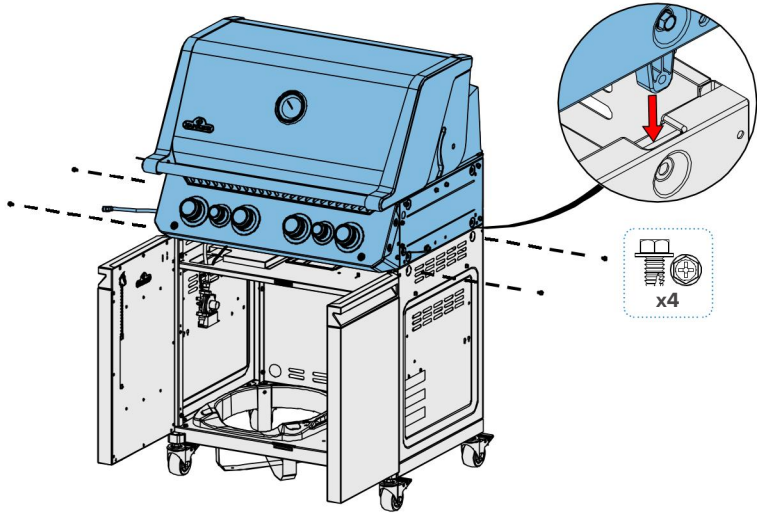

23

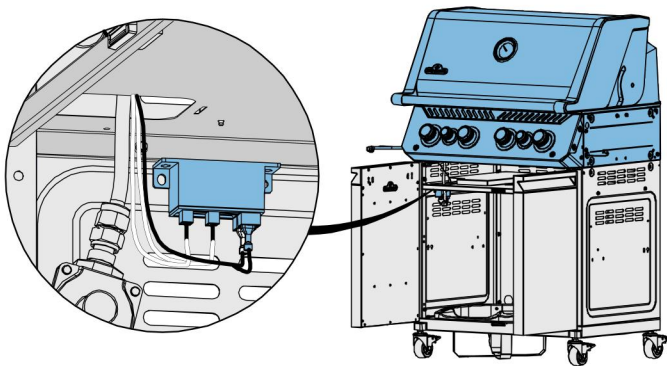

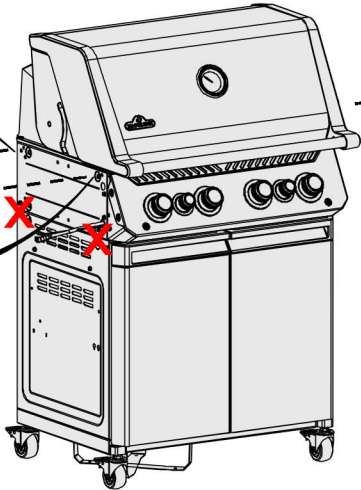
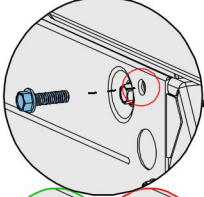
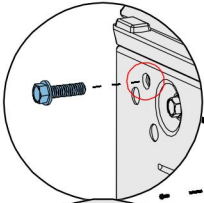
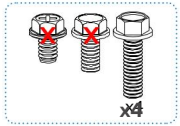

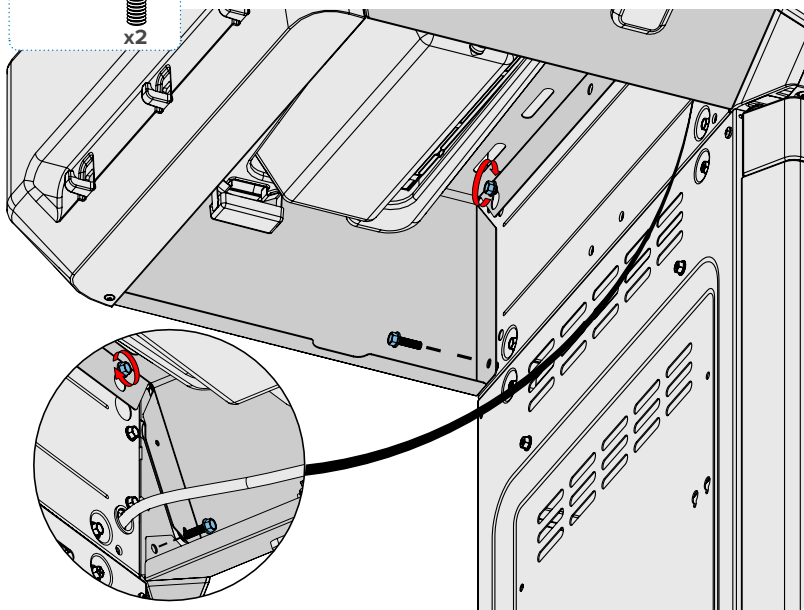
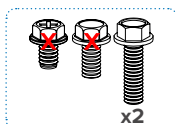
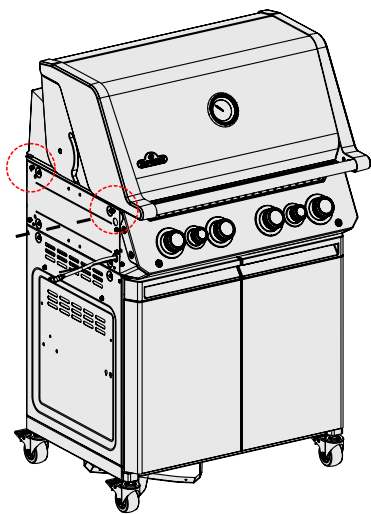
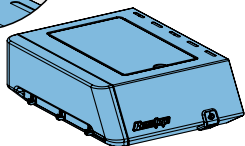
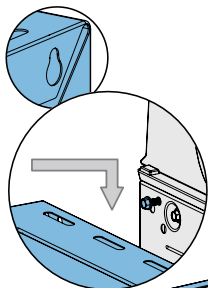

26

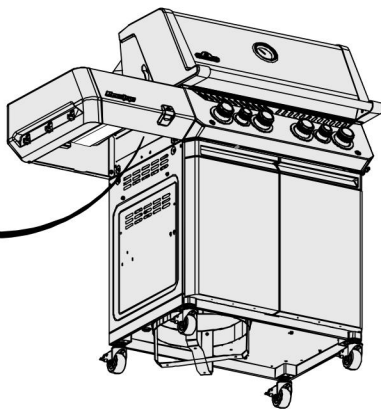
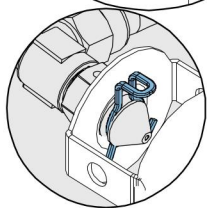
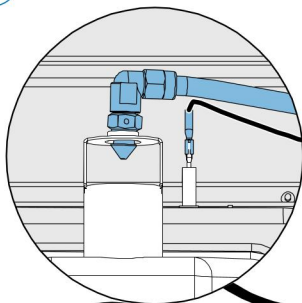

27

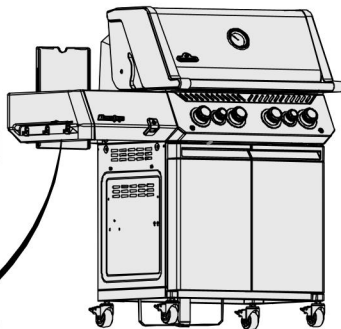
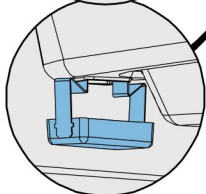
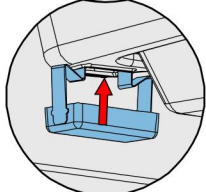
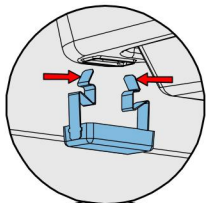

28

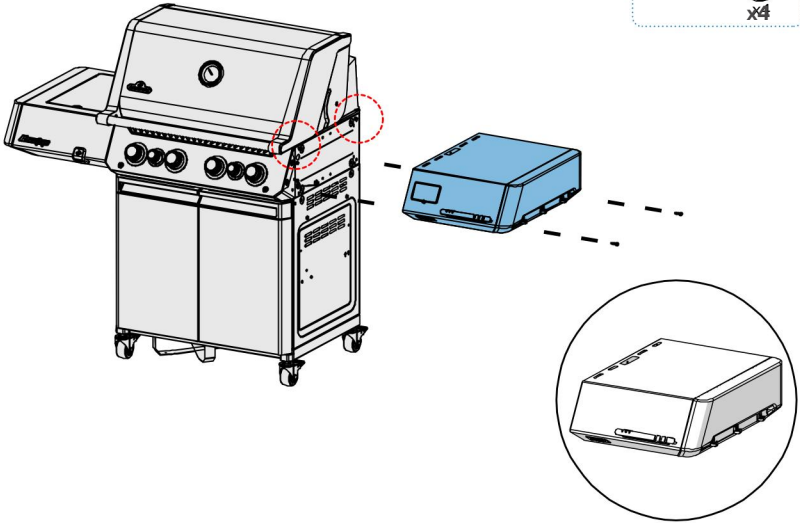
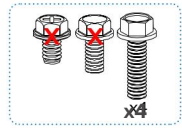

29

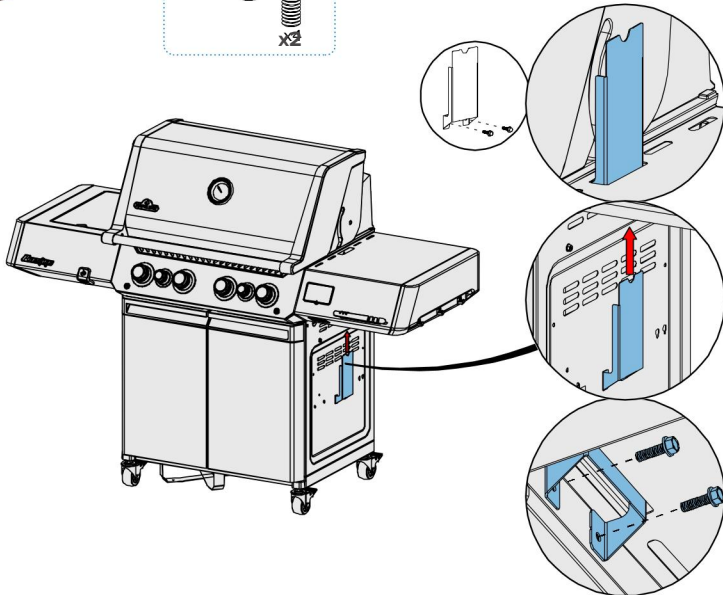
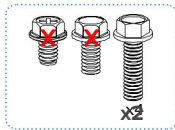

30

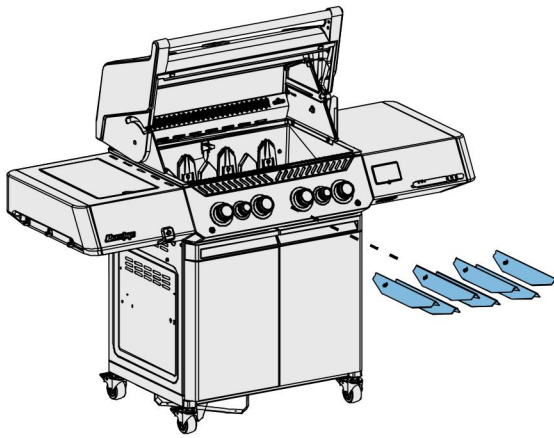

x7 P500

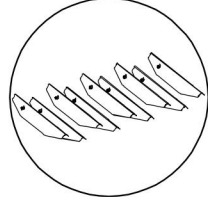
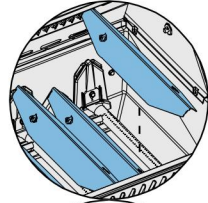

x9 P665

29

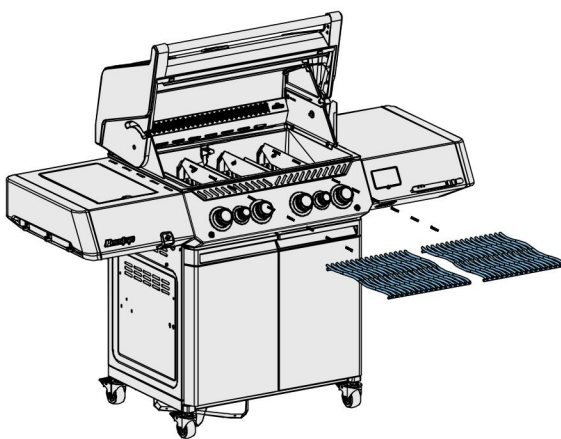

P500

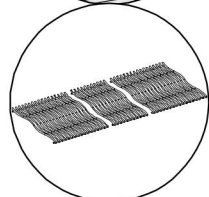
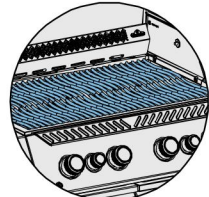

P665

32

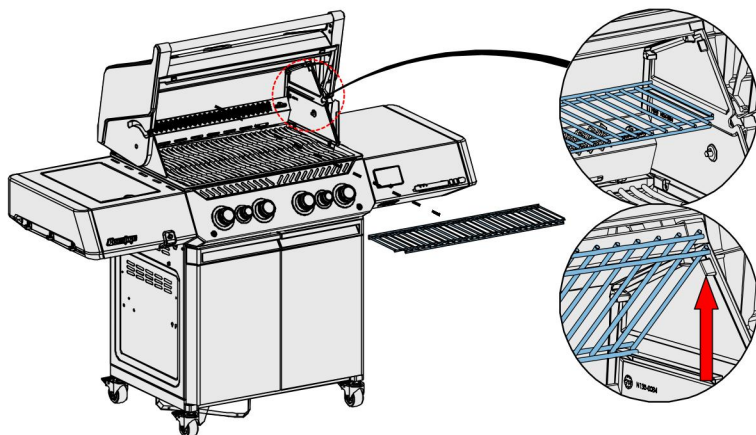

33

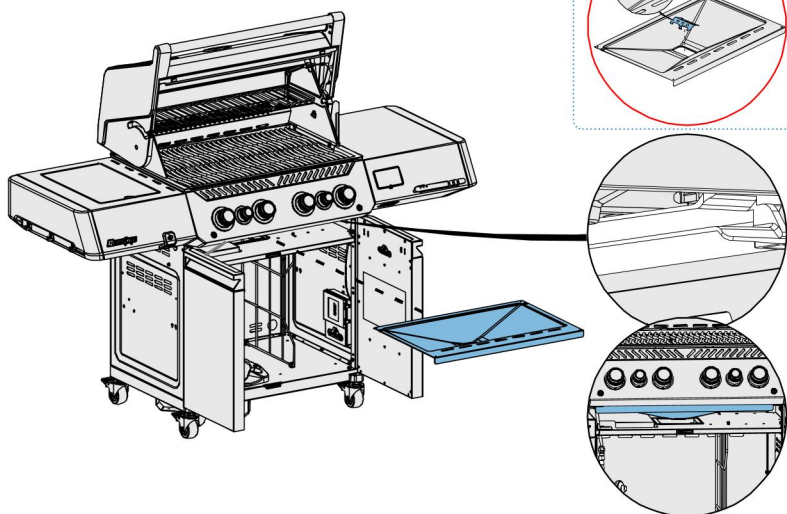

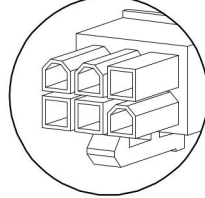
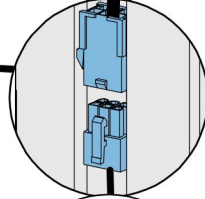
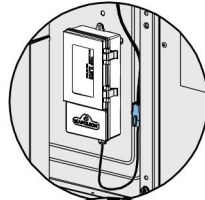
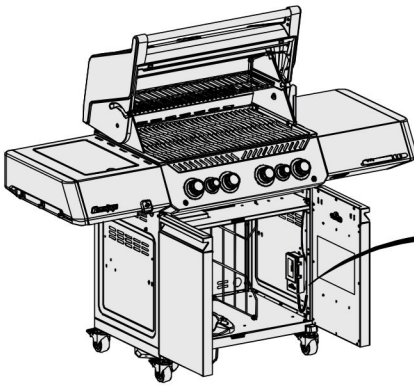

- EN Connect control panel wired harness to battery box.
- FR Connecter le faisceau de câbles du panneau de commande au boîtier de la batterie.
- ES Conecte el mazo de cables del panel de control a la caja de la batería.
- DE Den Kabelbaum der Steuertafel mit dem Batteriekasten verbinden.

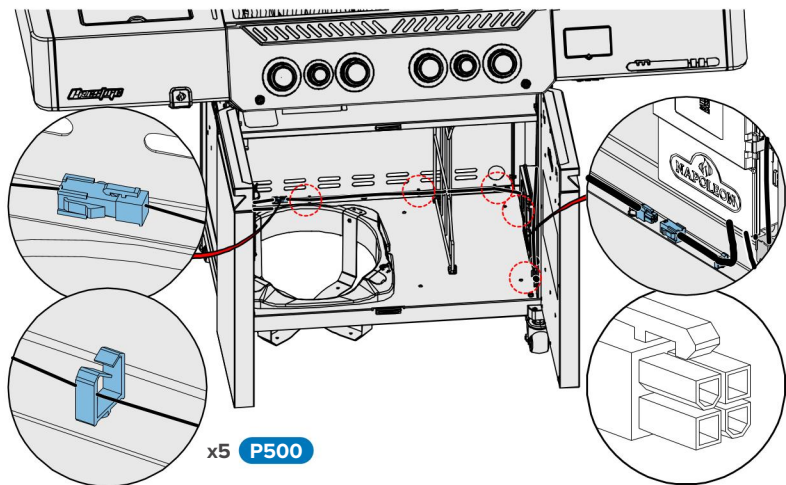

(EN) Connect the tank scale wire to the battery box.

(FR) Connecter le câble de la balance du réservoir au boîtier de la batterie.

(ES) Conecte el cable de la escala del depósito a la caja de la batería.

(DE) Schließen Sie das Kabel der Tankwaage an den Batteriekasten an.

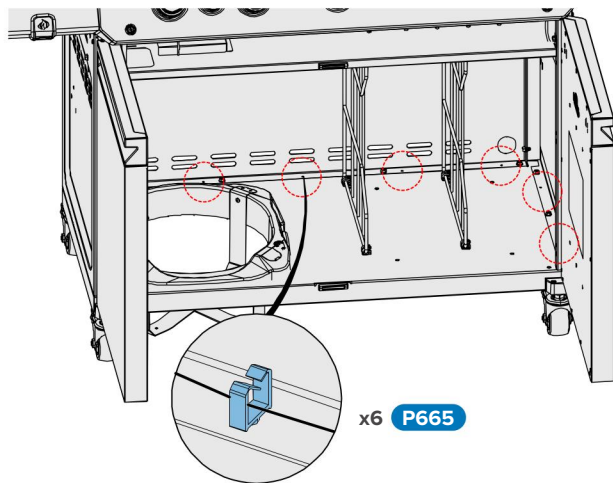

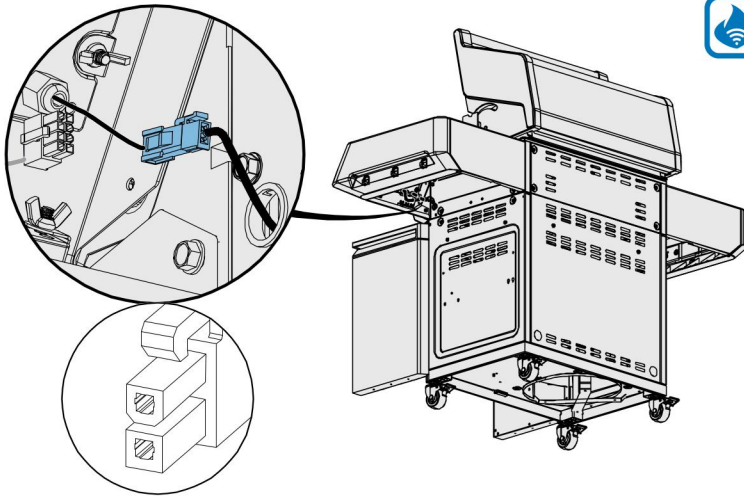

- EN Connect wire to LCD screen.
- FR Connecter le câble à l'écran LCD.
- ES Conectar el cable a la pantalla LCD.
- DE Schließen Sie das Kabel an den LCD-Bildschirm an.

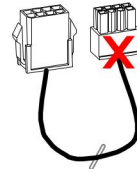
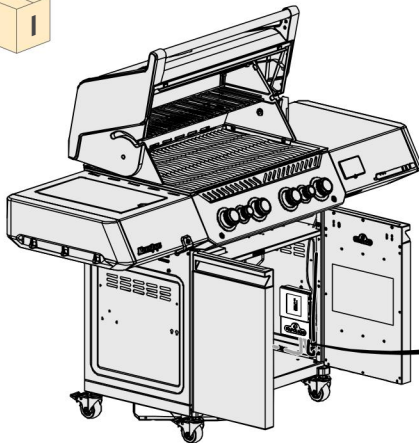

- EN Locate your wireharness, connect the female plug to the power box.
- FR Localisez votre faisceau de câbles, connectez la fiche femelle au boîtier électrique.
- ES Localice su mazo de cables, conecte el enchufe hembra a la caja de alimentación.
- DE Suchen Sie Ihren Kabelbaum und schließen Sie die Steckerbuchse an den Stromkasten an.

38

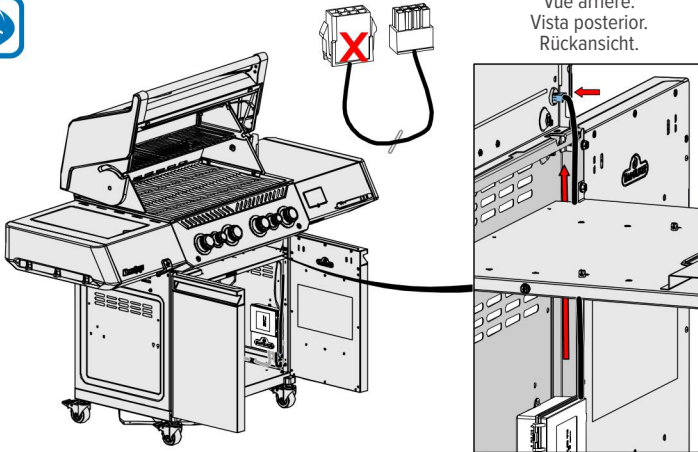

Back view.
Vue arrière.
Vista posterior.
Rückansicht.

- EN** Take the male end of the wire, feed it up through the front channel of the side panel and through the bushing on the right side.
- FR** Prenez l'extrémité mâle du fil, faites-la passer par le canal avant du panneau latéral et par la douille sur le côté droit.

- ES** Toma el extremo macho del cable, pásalo por el canal frontal del panel lateral y por el casquillo del lado derecho.
- DE** Nehmen Sie das männliche Ende des Kabels, führen Sie es durch den vorderen Kanal der Seitenwand und durch die Buchse auf der rechten Seite nach oben.

39

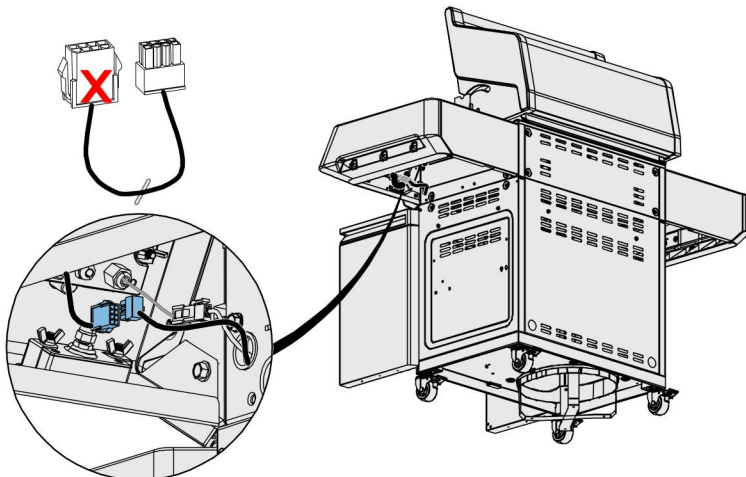

- EN** Connect the male end to the side shelf LCD screen.
- FR** Connecter l'extrémité mâle à l'écran LCD de l'étagère latérale.

- ES** Conecte el extremo macho a la pantalla LCD del estante lateral.
- DE** Verbinden Sie das männliche Ende mit dem LCD-Bildschirm des Seitenregals.

40

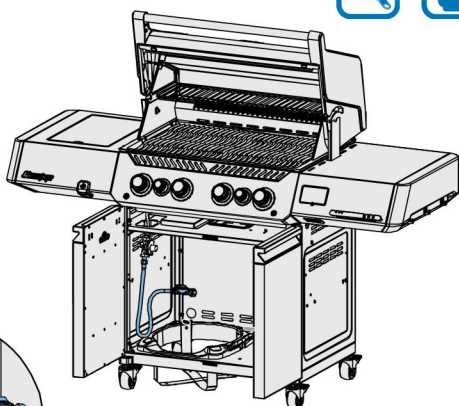
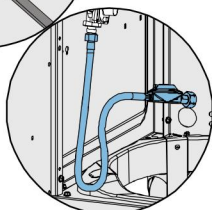
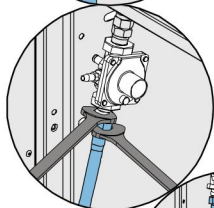
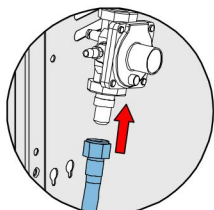

41

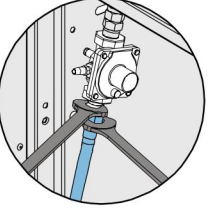
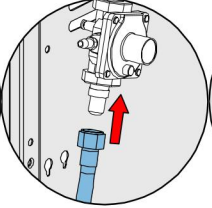
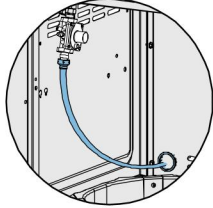
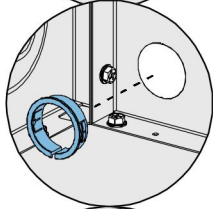
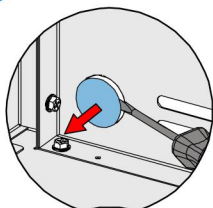

42

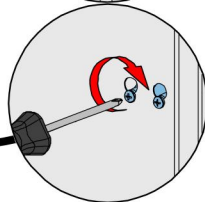
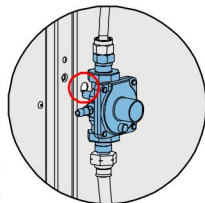
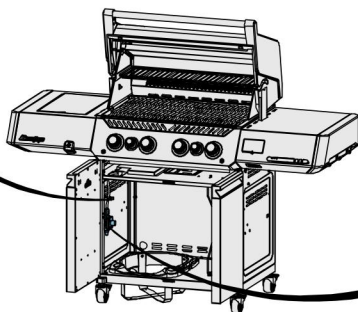
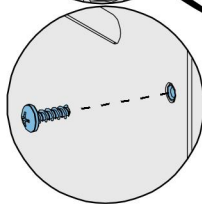
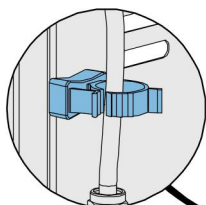

43

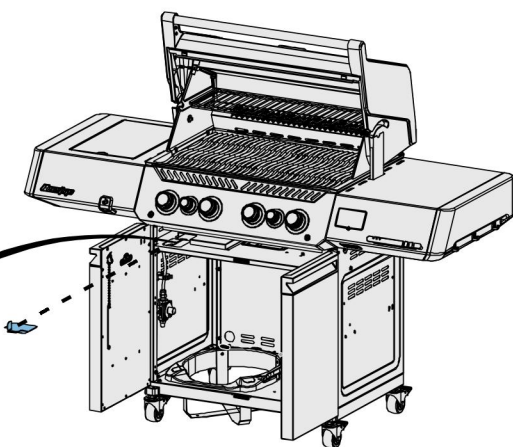
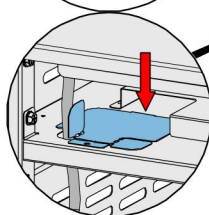
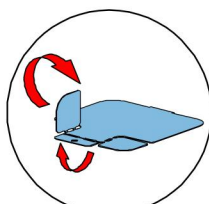

44

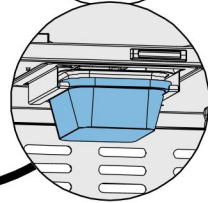
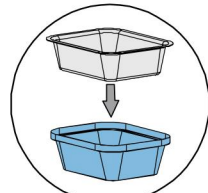

45

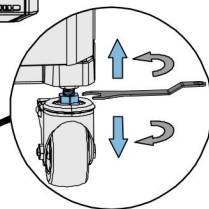
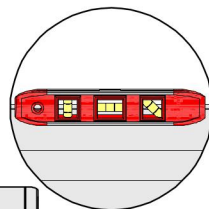
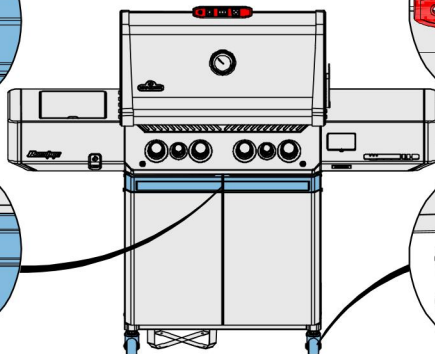
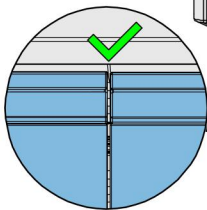
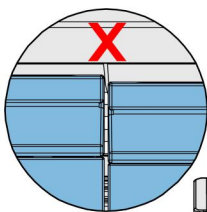

46

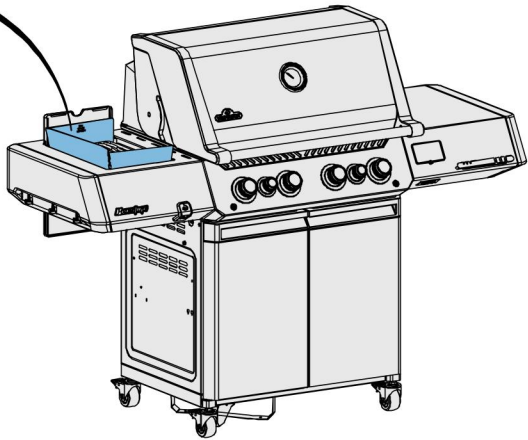
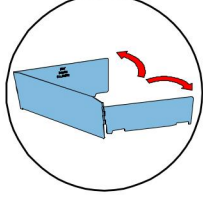
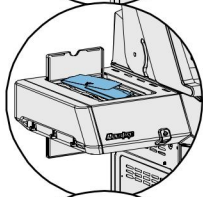
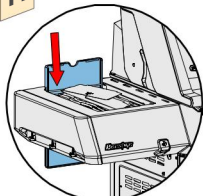

47

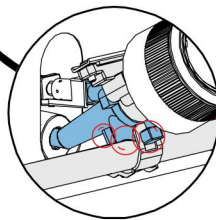
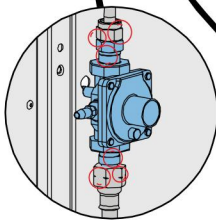
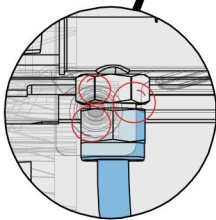
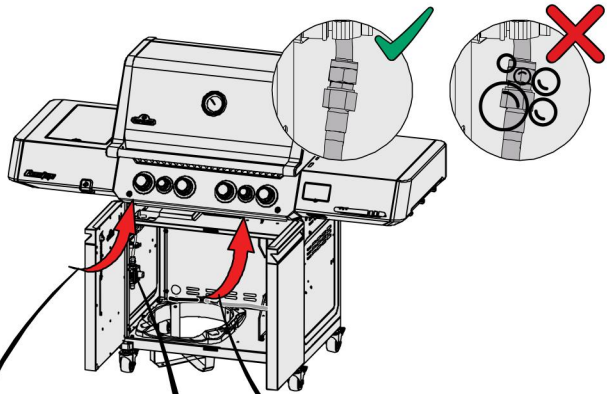



Grill Overview | Vue d'ensemble du grill Visión general de la parrilla | Grill Übersicht

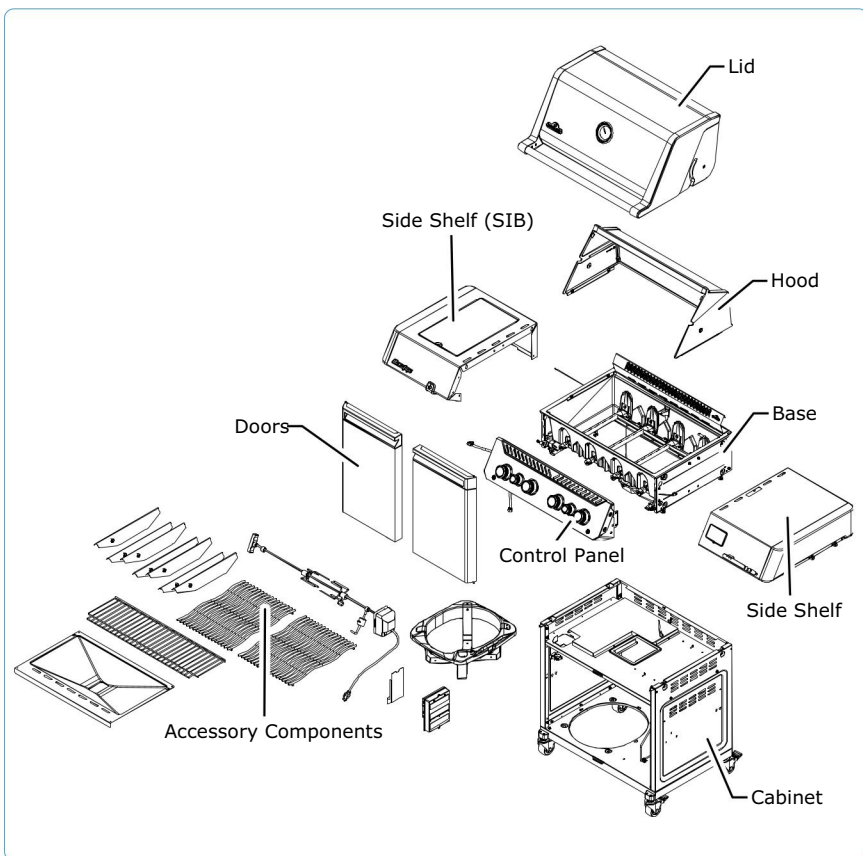

Legend

x - standard part
p - propane
n - natural
ac - accessory

Légende

x - standard
p - propane
n - gas naturel
ac - accessoire

Leyenda

x - estándar
p - propano
n - gas natural
ac - accesorio

Legende

x - Standardteil
p - Propan
n - natürlich
ac - Zubehör



PHM

- Phantom model parts
- Pièces du modèle Phantom
- Piezas del modelo Phantom
- Phantom Modellteile

Lid Assembly | L'assemblage du couvercle
 Ensamblaje de la tapa | Montage des Deckels

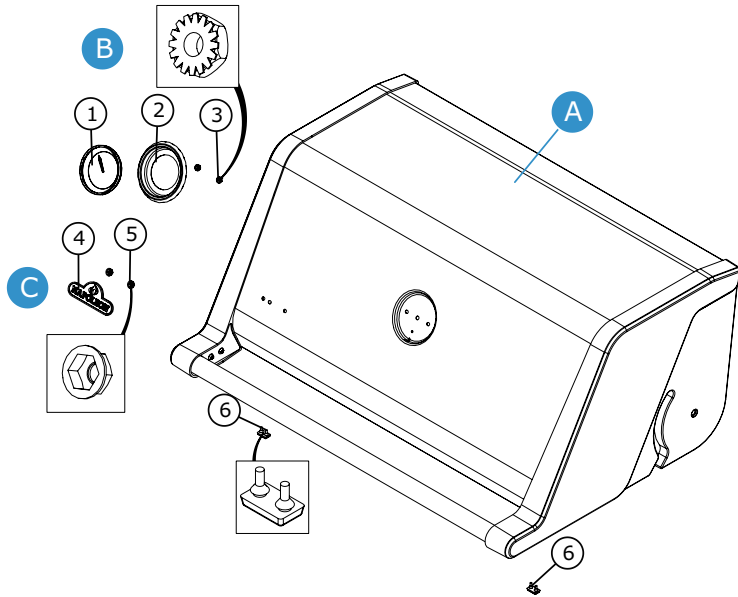

	Part #	P500V	P500VX	P500 PHM	P665V	P665VX	Description
A	N360-0011-SER	x	x				Lid Assembly. Assemblage du couvercle. Montaje de la tapa. Montage des Deckels.
A	N360-0012-SER				x	x	
A	N010-1743-SER			x			
B	N685-0032-SER	x	x		x	x	TEMPERATURE GAUGE KIT
B	N685-0032-BK-SER			x			
1	N685-0032	x	x		x	x	Temperature Gauge. Indicateur de température. Indicador de temperatura. Temperaturanzeige.
1	N685-0032-BK			x			
2	N051-10002238	x	x		x	x	Temperature Gauge Bezel. Couvercle de la jauge de température. Indicador de temperatura Bisel. Lünette der Temperaturanzeige.
2	N051-10002238-BK1HT			x			
3	N450-0032	x	x	x	x	x	Locknut. Contre-écrou. Tuerca de seguridad. Gegenmutter.
C	N385-0532-SER	x	x		x	x	LOGO KIT
C	N010-1744-SER			x			
4	N385-0532	x	x		x	x	Logo, Napoleon. Logo, Napoléon. Logotipo, Napoleón. Logo, Napoleon.
4	N385-0532-BK			x			
5	N450-0044	x	x	x	x	x	Nut Écrou Tuerca Nuss
6	N510-0013	x	x	x	x	x	Lid Bumper. Butoir du couvercle. Tope de la tapa. Deckel-Stoßstange.

Hood Assembly | Assemblage du capot
 Montaje de la campana | Montage der Haube

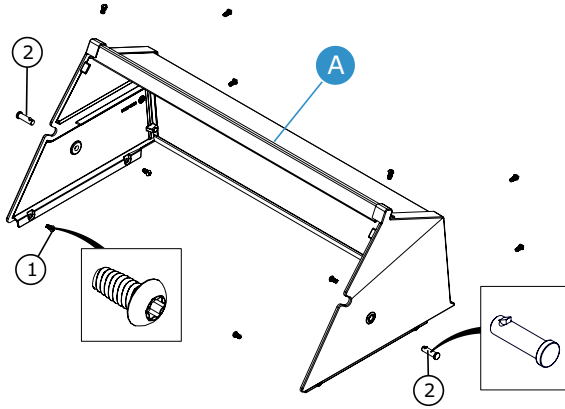

	Part #	P500V	P500VX	P500 PHM	P665V	P665VX	Description
A	N335-0151-SER	x	x				Hood Assembly. Assemblage du capot. Montaje de la campana. Montage der Haube.
A	N335-1745-SER			x			
A	N335-0152-SER				x	x	
1	N570-0145	x	x		x	x	Screw 1/4-20 x 1/2 in. Vis 1/4-20 x 1/2 in. Tornillo 1/4-20 x 1/2 in. Schraube
1	N570-0145-BK			x			
2	N485-0033	x	x	x	x	x	Pin, Clevis Locking. Goupille de verrouillage de chape. Perno, bloqueo de horquilla. Stift, Gabelkopferriegelung.

Side Shelf (Infrared Burner) | Tablette latérale (brûleur infrarouge) Estante lateral (quemador de infrarrojos) | Seitenablage (Infrarotbrenner)

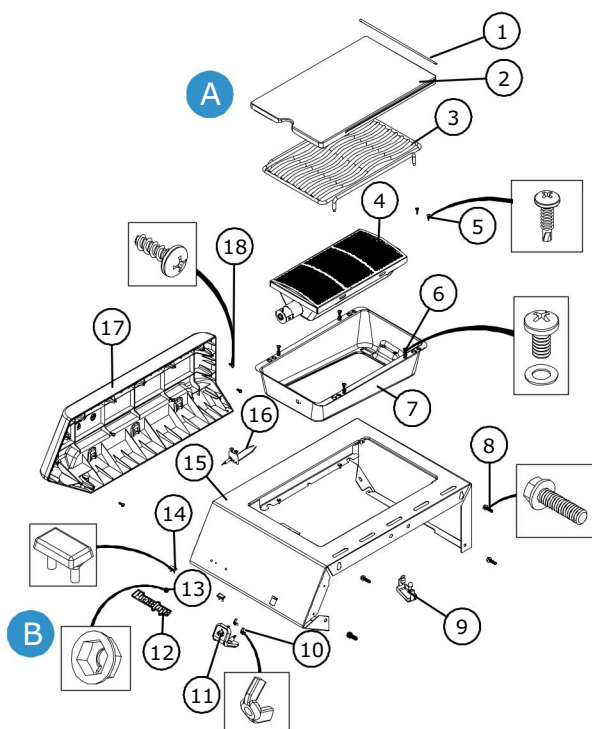

	Part #	P500V	P500VX	P500 PH-M	P665V	P665VX	Description
A	N010-1710	x	x		x	x	Assy, Side Shelf Left. Assemblage, tablette latérale gauche. Ensamblaje, estante lateral izquierdo. Montage, Seitenablage links.
A	N010-1710-BK			x			Assy, Side Shelf Left. Assemblage, tablette latérale gauche. Ensamblaje, estante lateral izquierdo. Montage, Seitenablage links.
1	N555-0091	x	x	x	x	x	Lid Rod. Tige de couvercle. Varilla de la tapa. Deckel-Stab.
2	N403-10001515-M02	x	x		x	x	Side Burner Lid. Couvercle du brûleur latéral. Tapa lateral del quemador. Seitenbrenner-Deckel.
2	N403-10001515-BK1TX			x			
3	N305-10001280	x	x		x	x	Cooking Grid Side Burner STN STL. Grille, ondulée, côté IR. Rejilla, Ondulada, lado IR. Kochrost Seitenbrenner Edelstahl
3	N305-0141			x			
4	N010-1725	x	x	x	x	x	Assy, Infrared Burner. Assemblage, brûleur infrarouge. Ensamblaje, quemador infrarrojo. Montage, Infrarot-Brenner.

	Part #	P500V	P500VX	P500 PHM	P665V	P665VX	Description
5	N570-0013	x	x	x	x	x	Screw Vis Tornillo Schraube #8 x 5/8 in ST.ST. Pan HD. Phil.
6	N570-0042, Z735-0001	x	x	x	x	x	Screw, 10-24 x 3/8 Rnd Hd Philip STN STL, NGZ, Washer M9 x 5mm x 0.5mm. Screw, 10-24 x 3/8 Rnd Hd Philip STN STL, NGZ, Rondelle M9x5mm x 0.5mm. Tornillo, 10-24 x 3/8 Rnd Hd Philip STN STL, NGZ, Arandela M9 x 5mm x 0.5mm. Schraube, 10-24 x 3/8 Rnd Hd Philip STN STL, NGZ, Unterlegscheibe M9 x 5mm x 0,5mm.
7	N500-0079-BK2GL	x	x	x	x	x	Infrared Side Burner Housing. Brûleur latéral infrarouge. Carcasa del quemador lateral infrarrojo. Gehäuse des Infrarot-Seitenbrenners.
8	N570-0087	x	x	x	x	x	Screw, 1/4-20 x 7/8 in. Vis, 1/4-20 x 7/8 in. Tornillo, 1/4-20 x 7/8 pulg. Schraube, 1/4-20 x 7/8 in.
9	N710-10001808	x	x	x	x	x	Side Burner Drip Tray. Plateau d'égouttage du brûleur latéral. Bandeja de goteo del quemador lateral. Tropfschale für Seitenbrenner.
10	N450-0051	x	x	x	x	x	Nut, Wing # 10-32. Écrou à ailettes # 10-32. Tuerca de mariposa # 10-32. Mutter, Flügel # 10-32.
11	N080-0518	x	x		x	x	Bottle Opener, Mounted. Décapsuleur, montage.
11	N080-0518-BKITX			x			Abridor de botellas, montado. Flaschenöffner, Montiert.
B	N385-0506-SER	x	x		x	x	Logo, Prestige with Nuts. Logo, Prestige avec écrous. Logotipo, Prestige con tuercas. Logo, Prestige mit Nüssen.
B	N385-0506-BK-SER			x			
12	N385-0506	x	x		x	x	Logo, Prestige.
13	N450-0044	x	x	x	x	x	Nut, 3/16 Stud. Écrou, boulon 3/16. Tuerca, perno 3/16. Mutter, 3/16 Bolzen.
14	N510-0013	x	x	x	x	x	Bumper, Rectangular. Pare-chocs, rectangle. Parachoques, rectangular. Stoßstange, rechteckig.
15	N010-1717	x	x		x	x	Side Shelf Left. Tablette latérale gauche.
15	N010-1717-BK			x			Estante lateral izquierdo. Seitenregal links.
16	N240-10002246	x	x	x	x	x	Electrode, IR Side Burner. Électrode, brûleur latéral IR. Electrodo, quemador lateral IR. Elektrode, IR-Seitenbrenner.
17	N120-0058	x	x		x	x	End Cap, Side Shelf Left. Embout, tablette latérale gauche. Tapa lateral izquierda. Endkappe, Seitenregal links.
17	N120-0058			x			
18	N570-0076	x	x	x	x	x	Screw, #8 x 1/2 in. Vis, #8 x 1/2 in. Tornillo, #8 x 1/2 pulg. Schraube, #8 x 1/2 in.

Base Assembly | Assemblage de la base Montaje de la base | Montage der Basis

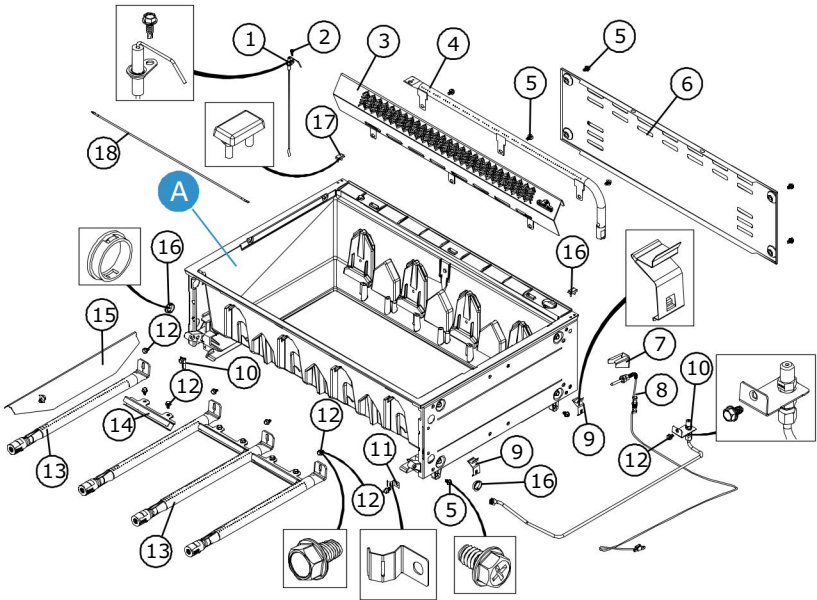

	Part #	P500V	P500VX	P500 PHM	P665V	P665VX	Description
A	N135-0085-SER	x	x				Base Assembly. Assemblage de la base. Montaje de la base. Montage der Basis
A	N135-0085-BK-SER			x			
A	N135-0086-SER				x	x	
1	N240-0046	x	x	x	x	x	Rear Burner Electrode (with Wire). Electrode du brûleur arrière (avec fil). Electrodo quemador trasero (con cable). Hintere Brenner Elektrode (mit Draht).
2	N570-0008	x	x	x	x	x	Screw, #8 x 1/2 in. Vis, #8 x 1/2 in. Tornillo, #8 x 1/2 pulg. Schraube, #8 x 1/2 in.
3	N350-0104	x	x	x			Housing, Rear Burner. Boîtier, brûleur arrière. Carcasa, quemador trasero. Gehäuse, hinterer Brenner.
3	N350-0105				x	x	
4	N100-0072	x	x	x	x	x	Burner, Rear. Brûleur, arrière. Quemador trasero. Brenner, hinten.
5	N570-0118	x	x	x	x	x	Screw, 1/4 - 20x3/8 Vis, 1/4 - 20x3/8 Tornillo, 1/4 - 20x3/8 Schraube, 1/4 - 20x3/8

	Part #	P500V	P500VX	P500 PH-M	P665V	P665VX	Description
6	N200-0157-GY1HT	x	x				Back Cover.
6	N200-0157-BK1HT			x			Couverture arrière.
6	N200-0158-GY1HT				x	x	Cubierta trasera. Hintere Umschlagseite.
7	N585-0192		x	x		x	Thermocouple Heat Shield. Bouclier thermique du thermocouple. Escudo térmico del termopar. Thermoelement-Hitzeschild.
8	N680-0002		x	x		x	Thermocouple, (with Wire). Thermocouple, (avec fil). Termopar, (con cable). Thermoelement, (mit Draht).
9	N160-0056	x	x	x	x	x	Spring Clip. Clip à ressort. Clip de resorte. Federklemme.
10	N010-1720	p	p	x			Assy, Rear Burner Orifice. Assy, Orifice du brûleur arrière. Ensam, Orificio quemador trasero. Baugruppe, hintere Brenneröffnung. P500V LPG.
10	N010-1721	n	n	x			Assy, Rear Burner Orifice. Orifice du brûleur arrière. Orificio quemador trasero. Baugruppe, hintere Brenneröffnung. P500V NAT.
10	N010-1722				p	p	Assy, Rear Burner Orifice. Assem, orifice du brûleur arrière. Ensam, orificio quemador trasero. Baugruppe, hintere Brenneröffnung. P665V GLP
10	N010-1723				n	n	Assy, Rear Burner Orifice. Assem, Orifice du brûleur arrière. Ensam, Orificio quemador trasero. Baugruppe, hintere Brenneröffnung. P665V NAT.
11	N160-0058 N570-0122	x	x	x	x	x	Bracket & Screw. Support et vis. Soporte y tornillo. Halterung & Schraube.
12	N570-0122	x	x	x	x	x	Screw. Vis. Tornillo. Schraube 1/4 -20 x 10.5 mm
13	N100-0071	x	x	x	x	x	Burner, Main Tube. Brûleur, tube principal. Quemador, tubo principal. Brenner, Hauptrohr.
14	N080-0406	x	x	x	x	x	Bracket, Cross Light. Support, éclairage transversal. Soporte, luz de cruce. Halterung, Kreuzleuchte.
15	N500-0080	x	x	x	x	x	Sear Plate. Plaque d'araignée, biseautée. Placa de cizalla, biselada. Anbratplatte.
16	N105-0023	x	x	x	x	x	Bushing 7/8 in. Douille 7/8 in. Casquillo 7/8 pulg. Buchse 7/8 in.
17	N510-0013	x	x	x	x	x	Bumper, Lid. Pare-chocs, Couvercle. Paragolpes, Tapa. Stoßstange, Deckel.
18	N750-1117	x	x	x	x	x	Wire, Side Burner Ignitor. Fil, allumage du brûleur latéral. Cable, ignitor quemador lateral. Draht, Seitenbrenner-Zünder.

Side Shelf | Tablette latérale | Estante lateral | Seitenablage

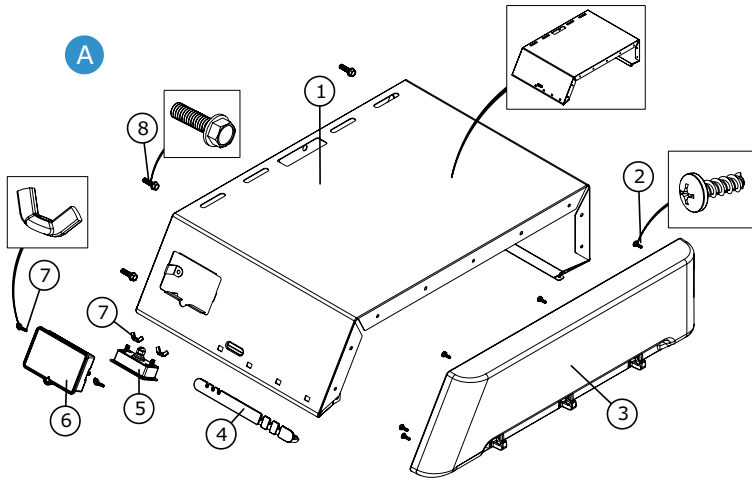

	Part #	P500V	P500VX	P500 PHM	P665V	P665VX	Description
A	N010-1711	x			x		Assy, Side Shelf Right.
A	N010-1712-CE		x			x	Assemblage, tablette latérale droite.
A	N010-1712-CE-BK			x			Ensamblaje, estante lateral derecho. Montage, Seitenablage rechts
1	N010-1718	x			x		Welded Side Shelf Right.
1	N010-1719		x			x	Tablette latérale soudée à droite.
1	N010-1719-BK			x			Estante lateral soldado a la derecha. Geschweißtes Seitenregal Rechts.
2	N570-0076	x	x	x	x	x	Screw Vis Tornillo Schraube #8x1/2 in.
3	N120-0059	x	x		x	x	End Cap, Side Shelf Right. Capuchon, tablette latérale droite. Tapa, estante lateral derecho. Endkappe, Seitenregal rechts.
3	N120-0059-BK0TX			x			
4	N710 -10002247		x			x	Tray, Side Shelf, Probe. Plateau, étagère latérale, sonde. Bandeja, estante lateral, sonda. Tablett, Seitenablage, Sonde.
4	N710 -10002247 -BK0T			x			
5	N460-0004		x	x		x	Receptacle, Probe Plugs. Réceptacle, bouchons de sonde. Receptáculo, conectores de sonda. Steckbuchse, Sondenstecker.
6	N010-1739		x	x		x	Display Assy. Assortiment d'affichage. Ensamblaje de la pantalla. Display-Montage.
7	W450-0051		x	x		x	Nut, Wing #10-32. Écrou à ailettes #10-32. Tuerca de mariposa #10-32. Mutter, Flügel #10-32
8	N570-0087	x	x	x	x	x	Screw, 1/4-20 x 7/8 in. Vis, 1/4-20 x 7/8 in. Tornillo, 1/4-20 x 7/8 pulg. Schraube, 1/4-20 x 7/8 in.

Control Panel | Panneau de contrôle | Panel de control | Bedienfeld

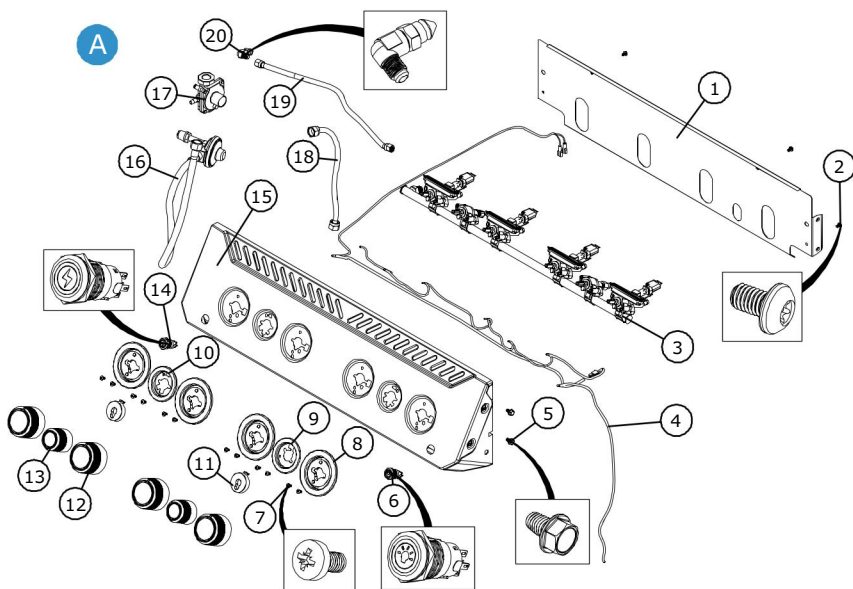

	Part #	P500V	P500VX	P500 PH-M	P665V	P665VX	Description
A	N475-0636-LP-SER	p	p				Control Panel Assy. Panneau de commande. Panel de control. Montage des Bedienfelds
A	N475-0636-NG-SER	n	n				
A	N475-0637-LP-SER				p	p	
A	N010-1742-LP-SER		p	p			
A	N010-1742-NG-SER		n	n			
A	N475-0637-NG-SER				n	n	
1	N585-0193	x	x	x			Shield, Heat Control Panel. Bouclier, panneau de contrôle de la chaleur. Escudo, panel de control térmico. Abschirmung, Wärmesteuerung.
1	N585-0194				x	x	
2	N570-0148	x	x	x	x	x	Screw, 10-32 x 5/16 in. Vis, 10-32 x 5/16 in. Tornillo, 10-32 x 5/16 pulg. Schraube 10-32 x 5/16 in.
3	N432-0023	p	p	p			Manifold Collecteur Colector Verteiler P500V(X) RSIB LPG.
3	N432-0024	n	n	p			Manifold Collecteur Colector Verteiler P500V(X) RSIB NAT.

	Part #	P500V	P500VX	P500 PHM	P665V	P665VX	Description
3	N432-0025				p	p	Manifold Collecteur Colector Verteiler P665V(X) RSIB LPG.
3	N432-0026				n	n	Manifold Collecteur Colector Verteiler P665V(X) RSIB NAT.
4	N010-1726	x	x	x			Control Panel Wire Harness. Harnais de câbles, panneau de commande. Mazo de cables del panel de control. Kabelbaum für die Steuertafel.
4	N010-1727				x	x	Control Panel Wire Harness. Harnais de câbles, panneau de commande. Mazo de cables del panel de control. Kabelbaum für die Steuertafel.
5	N570-0122	x	x	x	x	x	Screw, 1/4-20 x 10.5 mm. Vis, 1/4-20 x 10.5 mm. Tornillo, 1/4-20 x 10.5 mm. Schraube, 1/4-20 x 10.5 mm.
6	N660-0014	x	x	x	x	x	Light Switch. Interrupteur de lumière. Interruptor de luz. Lichtschalter.
7	N570-0078	x	x	x	x	x	Screw, M4 x 8 mm. Vis, M4 x 8 mm. Tornillo, M4 x 8 mm. Schraube, M4 x 8 mm.
8	N010-1713	x	x		x	x	Assy, Bezel + LED (Main Burner). Ensemble, cadre + LED (brûleur principal). Ensam, bisel + LED (quemador principal). Baugruppe, Blende + LED (Hauptbrenner)
8	N010-1713-BK			x			
9	N051-0027	x	x		x	x	Bezel, Small Rear Burner. Cadre, petit brûleur arrière. Bisel, quemador pequeño trasero. Blende, kleiner hinterer Brenner.
9	N051-10001479-BK1TX			x			
10	N051-0026	x	x		x	x	Bezel, Small Rear Burner. Cadre, petit brûleur arrière. Bisel, quemador pequeño trasero. Blende, kleiner hinterer Brenner.
10	N051-10001478-BK1TX			x			
11	N387-0016	x	x	x	x	x	LED, Blue/Red Small. LED, bleu/rouge petit. LED, azul/rojo pequeño. LED, Blau/Rot Klein.
12	N380-0051	x	x	x	x	x	Knob, Large Main Burner. Bouton, grand brûleur principal. Perilla, quemador grande principal. Knopf, großer Hauptbrenner.
12	N380-0051-BK						
13	N380-0052	x	x		x	x	Knob, Small Side/Rear Burner. Bouton, petit brûleur latéral/arrière. Perilla, pequeño quemador lateral/trasero. Knopf, kleiner Seiten-/Heckbrenner.
13	N380-0052-BK			x			
14	N660-0013	x	x		x	x	Igniter Button. Bouton d'allumage. Botón de encendido. Zündungstaste. Zündungstaste.
14	N660-0013-BK			x			
15	N475-0636	x	x				
15	N475-10001476-BK1HX			x			Panel, Control. Panneau de contrôle. Panel de control. Panel, Steuerung.
15	N475-0637				x	x	

	Part #	P500V	P500VX	P500 PHM	P665V	P665VX	Description
16	N530-0032	p	p	p	p	p	Regulator, Propane. Régulateur, Propane. Regulador, propano Regler, Propan.
16	N530-0033	p	p	p	p	p	
16	N530-0034	p	p	p	p	p	
16	N530-0035	p	p	p	p	p	
16	N530-0036	p	p	p	p	p	
16	N530-0037	p	p	p	p	p	
16	N530-0038	p	p	p	p	p	
16	N530-0039	p	p	p	p	p	
16	N530-0042	p	p	p	p	p	
16	N530-0043	p	p	p	p	p	
16	N530-0046	p	p	p	p	p	
17	N530-0023-SER	p	p	p	p	p	Regulator, Stepdown, Régulateur, Stepdown, Regulador, reductor, Regler, Abwärtsregler, 50mbar - 24,5mbar, LPG
17	N530-0026	n	n	n	n	n	Regulator, Stepdown, Régulateur, Stepdown, Regulador, reductor, Regler, Abwärtsregler, 18.5mbar, NAT
18	N720-0071				x	x	Flex Connector 1/2 in x 12 in. Connecteur Flex 1/2 in x 12 in. Conector flexible 1/2 pulg. x 12 pulg. Flexverbinder 1/2 in x 12 in.
18	N720-0044	x	x	x			Flex Connector, 12 x 3/8 in. Connecteur Flex, 12 x 3/8 in. Conector flexible, 12 x 3/8 pulg. Flexverbinder, 12 x 3/8 in.
19	N720-0097	x	x	x	x	x	Side Burner Flex Connector 1/4 in x 17 in. Connecteur flexible pour brûleur latéral 1/4 in x 17 in. Conector flexible para quemador lateral 1/4 pulg. x 17 pulg. Flexanschluss für Seitenbrenner 1/4 in x 17 in.
20	N010-10001866	n	n	n	n	n	Assy, 90 Deg Fitting, SB Orifice 1.65 mm NAT. Assemblage, raccord à 90 degrés, SB Orifice 1.65 mm NAT. Conjunto, Racor 90 Deg, SB Orificio 1,65 mm NAT. Baugruppe, 90-Grad-Verschraubung, SB Blende, 1,65 mm NAT.
20	N010-10001865	p	p	p	p	p	Assy, 90 Deg Fitting, SB Orifice #56 LPG. Assemblage, raccord à 90 degrés, orifice SB #56 LPG. Conjunto, racor de 90 grados, orificio SB n° 56 GLP. Baugruppe, 90-Grad-Verschraubung, SB-Düse #56 LPG.

Cabinet Assembly | Assemblage du cabinet Emsablaje del armario | Montage des Gehäuses

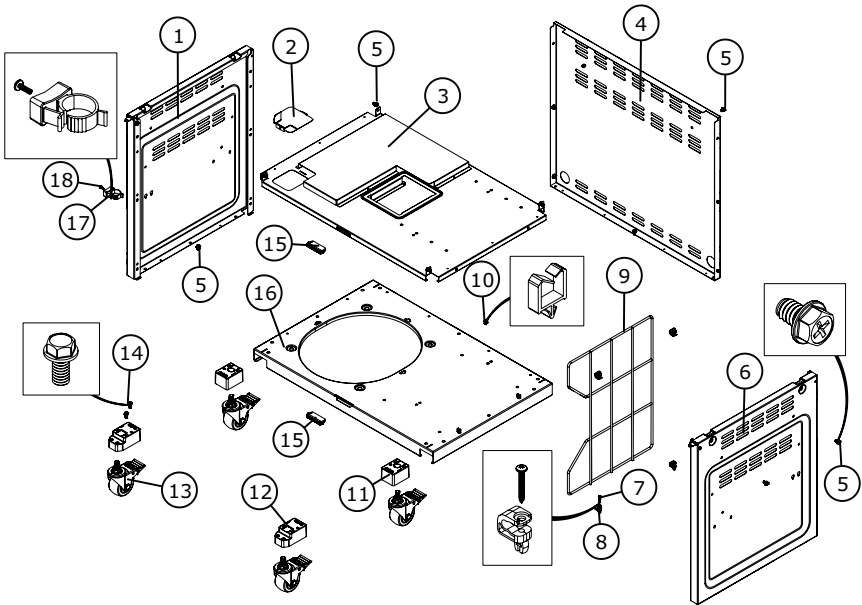

	Part #	P500V	P500VX	P500 PHM	P665V	P665VX	Description
1	N010-1728	x	x		x	x	Assy, Panel Cabinet Left. Assy, panel cabinet gauche. Ensamblaje, panel izquierdo. Montage, Schaltschrank links.
1	N010-1728-BX			x			
2	N200-0160-GY1SG	x	x		x	x	Cover, Heat Shield. Couvercle, bouclier thermique. Tapa, protección térmica. Abdeckung, Hitzeschild.
2	N200-0160-BK1TX			x			
3	N010-10001720-GY1SG	x	x				Shield, Heat Cart Gray. Bouclier, cartouche thermique gris. Escudo, carro térmico gris. Schild, Hitzewagen grau.
3	N010-10001720-BK1TX			x			
3	N010-10001721				x	x	
4	N475-0633-GY1SG	x	x				Panel, Rear Cart Gray. Panneau, arrière du chariot gris. Panel, carro trasero gris. Platte, hinterer Wagen Grau.
4	N475-0633-BK1TX			x			
4	N475-0634-GY1SG				x	x	
5	N570-0118	x	x	x	x	x	Screw Vis Tornillo 1/4-20 x 3/8 in.
6	N010-1729	x	x		x	x	Assy, Panel Cabinet Right. Assy, armoire à panneaux droite. Ensamblaje, armario panel derecho.
6	N010-1729-BX			x			

	Part #	P500V	P500VX	P500 PHM	P665V	P665VX	Description
7	N570-0154	x	x	x	x	x	Screw, #6 x 1 in. Vis, #6 x 1 in. Tornillo, #6 x 1 pulg. Schraube, #6 x 1 in.
8	N160-0057	x	x		x	x	Clip, Cart Divider. Clip, séparateur de chariot. Clip, separador de carros. Clip, Wageneinteilung.
8	N160-0057-BK0TX			x			
9	N222-0003	x	x		x	x	Divider, Cart. Séparateur, chariot. Separador, carro. Teiler, Wagen.
9	N222-0003-BK1TK			x			
10	W160-0057	x	x	x	x	x	Wire Clip. Clip de fil. Pinza para cables. Drahtklammer.
11	N655-0242	x	x	x	x	x	Support, Caster Rear. Support, crémaillère arrière. Soporte, ruedas traseras. Stütze, Lenkrad hinten.
12	N655-0241	x	x	x	x	x	Support, Caster Front. Support, roulette avant. Soporte, ruedas delanteras. Stütze, Lenkrad vorne.
13	N130-0018	x	x	x	x	x	Caster, 3 in Wheel, W/Brake. Roulette, 3 in wheel, avec le frein. Ruedas de 3 pulg., con freno. Lenkrolle, 3-Zoll-Rad, mit Bremse.
14	N570-0024	x	x	x	x	x	Screw, 1/4-20 x 1/2 Hex. Vis, 1/4-20 x 1/2 hexagonale. Tornillo, 1/4-20 x 1/2 hexagonal. Schraube, 1/4-20 x 1/2 Sechskant
15	N430-0009	x	x	x	x	x	Catch, Magnetic. Loquet, magnétique. Cierre magnético. Fangen, Magnetisch.
16	N590-10003348-GY1SG	p	p				Shelf, Bottom Cart P500V LPG Grey. Étagère, chariot inférieur P500V LPG gris. Estante, carro inferior P500V LPG gris. Regal, unterer Wagen P500V LPG Grau.
16	N590-0357-GY1SG	n	n				Shelf, Bottom Cart P500V NAT Grey. Étagère, chariot inférieur P500V NAT gris. Estante, carro inferior P500V NAT gris. Regal, unterer Wagen P500V NAT Grau.
16	N590-10003350-GY1SG				p	p	Shelf, Bottom Cart P665V LPG Grey. Étagère, chariot inférieur P665V LPG gris. Estante, carro inferior P665V LPG gris. Regal, unterer Wagen P665V LPG Grau.
16	N590-0359-GY1SG				n	n	Shelf, Bottom Cart P665V NAT Grey. Étagère, chariot inférieur P665V NAT gris. Estante, carro inferior P665V NAT gris. Regal, unterer Wagen P665V NAT Grau.
16	N590-10003348-BK1TX			p			Shelf, Bottom Cart P500V LPG Grey. Étagère, chariot inférieur P500V LPG gris. Estante, carro inferior P500V LPG gris. Regal, unterer Wagen P500V LPG Grau.

	Part #	P500V	P500VX	P500 PHM	P665V	P665VX	Description
16	N590-0357-BK1TX			n			Shelf, Bottom Cart P500V NAT Grey. Étagère, chariot inférieur P500V NAT gris. Estante, carro inferior P500V NAT gris. Regal, unterer Wagen P500V NAT Grau.
17	N160-0053	x	x	x	x	x	Clip, Flex Line Adjustable. Clip, flex ligne réglable. Clip, línea flexible ajustable. Clip, Flex Line einstellbar.
18	Z570-0043	x	x	x	x	x	Screw, #8 x 3/8 in Black. Vis, #8 x 3/8 in noir. Tornillo, #8 x 3/8 in, negro. Schraube, #8 x 3/8 in Schwarz.

Accessory Components | Composants auxiliaires
Componentes auxiliares | Zubehörkomponenten

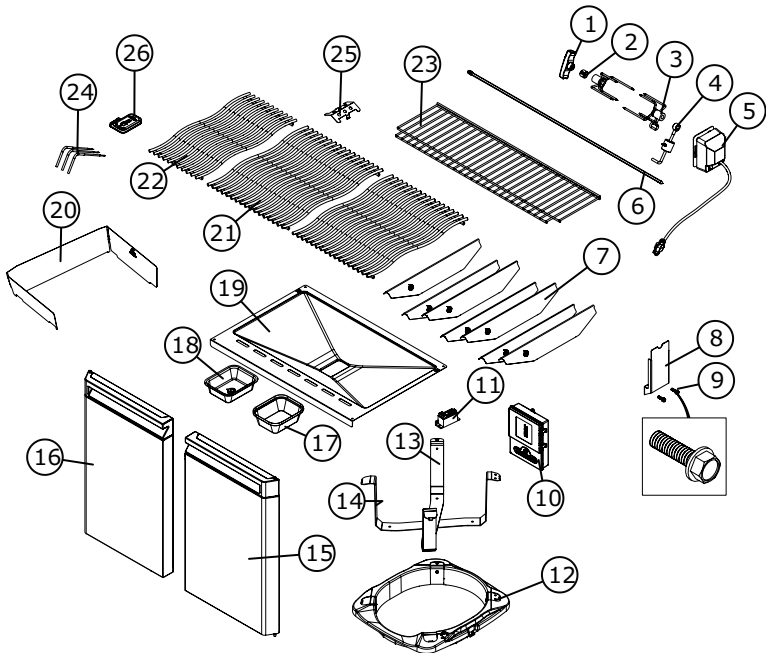

	Part #	P500V	P500VX	P500 PHM	P665V	P665VX	Description
1	N325-0079	x	x	x	x	x	T Handle Plastic For Spit Rod. Poignée en T en plastique pour crachoir. Mango en T de plástico para caña de escupir. T-Griff aus Kunststoff für Spucknapf.
2	N105-0019	x	x	x	x	x	Bushing, Stop. Douille, butée. Casquillo, Tope. Buchse, Anschlag.
3	N275-0001	x	x	x	x	x	Rotisserie Forks. Fourchettes de rôtisserie. Tenedores de asador. Rotisserie-Gabeln.
4	N370-0308	x	x	x	x	x	Counter Balance. Contre-équilibré. Contrapeso. Gegengewicht.
5	65033	x	x	x	x	x	Motor, Rotisserie Commercial, GB. Moteur, rôtissoire commerciale, GB. Motor, Asador Comercial, GB. Motor, Rotisserie Gewerblich, GB.
5	65032	x	x	x	x	x	Motor, Rotisserie Commercial, CE. Moteur, rôtissoire commerciale, CE. Motor, Asador Comercial, CE. Motor, Rotisserie Gewerblich, CE.

	Part #	P500V	P500VX	P500 PHM	P665V	P665VX	Description
6	N555-0038	x	x	x			Spit, Rod 34in. Embout, tige 34in. Spit, Varilla 34pulg. Spieß, Stab 34in.
6	N555-0060				x	x	Spit Rod, 43.5in. Tige filetée, 43.5in. Varilla cromada hexagonal 43.5 plug. Spieß, Stab 43.5in.
7	N500-0080	x	x	x	x	x	Sear Plate, Beveled. Plaque d'araignée, biseautée. Placa de cizalla, biselada. Anbratplatte, abgeschrägt.
8	N080-0519	x	x	x	x	x	Bracket, Mount Rotis Motor. Support, montage du moteur rotatif. Soporte, montaje de motor rotis. Halterung, Montage Rotis Motor.
9	N570-0087	x	x	x	x	x	Screw, 1/4-20 x 7/8 in. Vis, 1/4-20 x 7/8 in. Tornillo, 1/4-20 x 7/8 pulg. Schraube, 1/4-20 x 7/8 in.
10	N350-0106	x			x		Battery Housing 3x D-cell. Boîtier de batterie 3x D-cell. Carcasa de batería 3x D-cell. Batteriegehäuse 3x D-Zelle.
10	N010-1737		x	x		x	Battery Housing 6x D-cell. Boîtier de batterie 6x D-cell. Carcasa de batería 6x D-cell. Batteriegehäuse 6x D-Zelle.
11	N357-0021LY	x	x	x	x	x	Igniter, Block 2 Spark 4.5V. Allumeur, bloc 2 spark 4.5V. Encendedor, bloque 2 chispa 4.5V. Zünder, Block 2 Funken 4,5 V.
12	N010-10003347		p			p	Assy, Propane Tank Scale. Assemblage, Réservoir de propane échelle. Ensamblaje, tanque de propano escala. Montage, Propantank Skala.
12	N750-1115		p	p		p	Wire, Tank Scale To Battery. Fil, échelle de réservoir à la batterie. Cable, escala de tanque a batería. Draht, Tankwaage zur Batterie.
12	N710-10003304- GY0TX	p			p		Propane Tank Tray. Bac pour réservoir de propane. Bandeja de tanque de propano. Propan-Tankwanne.
12	N010-10003347- BK			p			Assy, Propane Tank Scale. Assemblage, Réservoir de propane échelle. Ensamblaje, tanque de propano escala. Montage, Propantank Skala.
13	N080-10003342- GY1SG	p	p		p	p	Bracket, CE Tank Scale right grey. Support, CE Tank Scale droit gris. Soporte, CE Tank Scale gris derecho. Halterung, CE- Tankwaage rechts grau.
13	N080-10003341- GY1SG	p	p		p	p	Bracket, CE Tank Scale left grey. Support, CE Tank Scale gauche gris. Soporte, CE Tank Scale gris izquierdo. Halterung, CE- Tankkala links grau.

	Part #	P500V	P500VX	P500 PHM	P665V	P665VX	Description
14	N080-10003341-BK1SG			p			Bracket, CE Tank Scale left black. Support, CE Tank Scale gauche noir. Soporte, CE Tank Scale izquierdo negro. Halterung, CE Tankwaage links schwarz.
14	N080-10003342-BK1SG			p			Bracket, CE Tank Scale right black. Support, CE Tank Scale droit noir. Soporte, CE Tank Scale derecho negro. Halterung, CE Tankwaage rechts schwarz.
15	N010-1700	x	x				Assy, Door Left. Assemblage, porte gauche. Ensamblaje, puerta izquierda. Montage, Tür links.
15	N010-1700-BX			x			
15	N010-1701	x	x				Assy, Door Right. Assemblage, porte droite. Ensamblaje, puerta derecha. Montage, Tür rechts.
15	N010-1701-BX			x			
16	N010-1702				x	x	Assy, Door Left. Assemblage, porte gauche. Ensamblaje, puerta izquierda. Montage, Tür links.
16	N010-1703				x	x	Assy, Door Right. Assemblage, porte droite. Ensamblaje, puerta derecha. Montage, Tür rechts.
17	62007	x	x	x	x	x	Alum. Foil Grease Tray. Bac à graisse en aluminium. Bandeja de grasa de aluminio. Alufolien-Fettauffangwanne.
18	N710-0062	x	x	x	x	x	Grease Tray. Plateau à graisse. Bandeja para grasa. Fettauffangwanne.
19	N010-10003432	x	x	x			Assy, Drip pan with Heat Shield. Assemblage, lèchefrite avec protection contre la chaleur. Montaje, bandeja de goteo con protección térmica. Montage, Tropfschale mit Hitzeschild.
19	N010-10003433				x	x	
20	N010-10001081	x	x	x	x	x	Side Burner Wind Shield. Brûleur latéral Pare-vent. Rompevientos, quemador lateral. Windschutz für Seitenbrenner.
21	N305-0157	x	x		x	x	Cooking Grid Large Stainless Steel. Grande grille de cuisson, acier inoxydable. Parrilla de cocción grande, acero inoxidable. Kochrost groß Edelstahl.
22	N305-0158				x	x	Cooking Grid Small Stainless Steel. Petite grille de cuisson, acier inoxydable. Parrilla de cocción pequeña, acero inoxidable. Kochrost Klein Edelstahl.
22	N305-0140 (x4)			x			
23	N520-0059	x	x				Warming Rack. Portoir chauffant. Soporte para calentar. Warmhaltegestell.
23	N520-0060				x	x	

	Part #	P500V	P500VX	P500 PHM	P665V	P665VX	Description
23	71500			x			Multifunctional Warming Rack. Panier chauffant multifonctionnel. Soporte de calentamiento multifuncional. Multifunktionales Warmhaltegestell.
24	N680-0003		x	x		x	Thermoprobe, Wired. Thermosonde, filaire. Sonda térmica, con cable. Thermoprobe, verdrahtet.
25	N215-10002068	x	x	x	x	x	Wind Deflector. Déflecteur de vent. Deflector de viento. Windabweiser.
26	N350-10002764		x	x		x	Probe Housing. Boîtier de la sonde. Carcasa de la sonda. Sondengehäuse.

NAPOLEON®

Celebrating over 40 years
delivering home comfort products

Célébrant plus de 40 ans à fournir des
produits de confort pour la maison

Celebrando más de 40 años entregando
productos para el confort del hogar

Wir feiern über 40 Jahre
Lieferung von Produkten für den Wohnkomfort



NAPOLEON® products are protected by one or more U.S. and Canadian and/or foreign patents or patents pending.

Les produits de NAPOLEON® sont protégés par un ou plusieurs brevets américains, canadiens et/ou étrangers au par des brevets en instance.

Los productos NAPOLEON® están protegidos por una o más patentes o patentes pendientes en E.U., Canadá y/u otros países.

NAPOLEON®-Produkte sind durch ein oder mehrere US-amerikanische und kanadische und/oder ausländische Patente oder angemeldete Patente geschützt.



Address

Wolf Steel Ltd.

De Riemsdijk 22, 4004 LC, Tiel, The Netherlands
10-12 Home Farm, Meriden Road, Berkswell,
CV7 7SL, United Kingdom
24 Napoleon Road, Barrie, Ontario,
L4M 0G8, Canada



Phone

Europe
+31 345 588655

Online

Email: eu.info@napoleon.com
Website: www.napoleon.com